

# OPERATING INSTRUCTIONS

## ADR Touch Control PRO

<b>ELE International</b> Chartmoor Road, Chartwell Business Park Leighton Buzzard, Bedfordshire, LU7 4WG England phone: +44 (0) 1525 249200 fax: +44 (0) 1525 249249 email: <a href="mailto:ele@eleint.co.uk">ele@eleint.co.uk</a> <a href="http://www.ele.com">http://www.ele.com</a> ELE International, a division of Hach Lange Ltd.	<b>Distributor:</b>	<b>ELE International</b> Soiltest Product Division PO Box 389, 5600 Lindbergh Drive Loveland, CO 80539 USA phone: +1 (970) 663 9780 fax: +1 (970) 663 9781 email: <a href="mailto:soiltest@eleusa.com">soiltest@eleusa.com</a> <a href="http://www.eleusa.com">http://www.eleusa.com</a>
<p><i>In the interests of improving and updating its equipment, ELE reserves the right to alter specifications to equipment at any time.</i></p> <p><b>ELE International 2020 ©</b></p>		

<b>Contents</b>	<b>Page</b>
<b>1 Specification</b>	<b>7</b>
<b>2 Introduction</b>	<b>11</b>
2.1 Compression Frames	11
2.2 Upper Platen Assemblies	16
2.3 Flexural and Transverse Frames	16
<b>3 Installation</b>	<b>16</b>
3.1 Moving, Lifting and Siting	16
3.1.1 Moving, Lifting and Siting the 250/25 Compression Frame	
3.1.2 Moving, Lifting and Siting the 2000 kN and 3000 kN Compression Frames	
3.1.3 Moving, Lifting and Siting the Console	
3.2 Connecting the Compression Frame to the Console	17
3.2.1 Connecting the Door Guard/Ram Travel Limit Switch	
3.3 Electrical Connections	17
3.3.1 Emergency Stop	
3.3.2 Connecting the Hydraulics	
3.4 Preparing the Hydraulics	18
3.4.1 Checking the Oil Level	
3.4.2 Bleeding the Hydraulic System	
3.5 Distance Pieces	19
<b>4 ADR Touch Control PRO Console</b>	<b>21</b>
4.1 Foreword	21
4.2 Turning the ADR Touch Control PRO On	21
4.2.1 Initial Display	
4.3 Front Panel Display and Controls	22
4.3.1 Display	
4.3.2 Home Screen Keys	
4.3.3 Touch Screen Brightness Setting	
4.3.4 Key Click Beeper	
4.3.5 General Settings	
4.3.5.1 Setting the Time and Date	
4.3.5.2 Setting the Language	
4.3.5.3 Display Units	

---

	4.3.5.4	Display Version	
	4.3.5.5	Save Log	
4.4		ADR Touch Control PRO Measurement Modes	27
4.5		Configuring the ADR Touch Control PRO's Operating Modes	27
	4.5.1	Selecting the Operating Mode	
	4.5.1.1	Dual Pace	
	4.5.1.2	Dual Sensor	
	4.5.2	Defining the Operating Mode Options	
	4.5.2.1	Failure Level	
	4.5.2.2	Failure Threshold	
	4.5.2.3	Zero Suppression	
	4.5.2.4	Tare Limit	
	4.5.2.5	Close Threshold and Control	
	4.5.3	User-Defined Settings	
	4.5.3.1	Folder for Tests	
	4.5.3.2	Test Data Settings	
	4.5.3.3	Pace Bar Width	
	4.5.3.4	Comms Port Settings	
	4.5.3.5	Verify Mode	
	4.5.4	Selecting the Sample Type and Size	
	4.5.4.1	Sample Types	
	4.5.4.2	Sample Sizes	
	4.5.4.3	Sample Favourites Option	
	4.5.4.4	Editing Values	
	4.5.4.5	Editing Sample Size	
	4.5.4.6	Editing the Pace Rate	
	4.5.4.7	Sample Density Values	
	4.5.5	Default Settings	
4.6		Running a Test	40
	4.6.1	Setting the Reference	
	4.6.2	Setting the Pace Rate	
	4.6.2.1	Dimensions	
	4.6.3	Starting Pacing	
	4.6.4	Pacing Control	

---

	4.6.4.1	Automatic	
	4.6.4.2	Board	
	4.6.5	Pace Error Bar Display	
	4.6.6	Altering the Pace Rate whilst the Test is Running	
	4.6.7	Pausing the Test	
	4.6.8	Overload Conditions	
	4.6.9	Ram Run-out Conditions	
	4.6.10	Safety Gate Interlock	
	4.6.11	Methods of Stopping a Test	
	4.6.12	Stopping the Test Manually	
	4.6.13	Sample Failure	
	4.6.14	Printing the Test Results	
4.7		ACV and TFV Tests	50
4.8		Recorded Test Results	50
	4.8.1	Downloading Test Data	
4.9		Verifying the Measurements	51
4.10		Configuring the Printer	51
4.11		Calibrating and Testing the ADR Touch Control PRO	52
4.12		Data Retention and Backup	52
	4.12.1	Real Time Clock	
	4.12.2	Configuration Data	
4.13		Error Conditions and Messages	52
4.14		Communications Interface (RS232)	52
	4.14.1	Baud Rate	
	4.14.2	Format	
	4.14.3	Terminator	
4.15		Rear Panel Connections	53
	4.15.1	AC Power Input	
	4.15.2	Door Guard/Ram Travel Limit Switch Inputs	
	4.15.3	Manual Control	
	4.15.4	Serial Port	
	4.15.5	USB Port	
	4.15.6	Updating the Firmware	

<b>5</b>	<b>ELE Logger</b>	<b>55</b>
5.1	System Requirements	55
5.2	Installing the ELE Logger Software	56
5.3	Direct Connection to the ADR Touch Control PRO (Point-to-Point), PC Configuration	56
5.4	Connecting the ADR Touch Control PRO to a Local Area Network	57
5.5	Configuring the Ethernet Comms	57
5.6	Running the ELE Logger	57
<b>6</b>	<b>Maintenance</b>	<b>61</b>
6.1	Daily	61
6.2	Occasionally	61
6.3	Verification	61
<b>7</b>	<b>Service and Spares</b>	<b>61</b>
<b>8</b>	<b>Rectangular Platen Handling Assemblies</b>	<b>61</b>
8.1	Introduction	61
8.2	Specification	62
8.3	Installation	62
	8.3.1 General	
	8.3.2 Lower Platen	
	8.3.3 Upper Platen	
8.4	Operation	63
	8.4.1 Block Testing	
	8.4.2 Cube Testing	
8.5	Maintenance	63
<b>Fig. 7.1</b>	Sectioned side view of load frame fitted with Rectangular Platen Handling Assembly	64
<b>Fig. 7.2</b>	Rear view of load frame fitted with Rectangular Platen Handling Assembly	64
<b>Fig. 7.3</b>	Set up for testing blocks requiring less than maximum vertical clearance	65
<b>Fig. 7.4</b>	Set up for testing 150 mm cubes	65

<b>Appendix 1</b>	<b>Sample Types and Sizes</b>	<b>66</b>
	Cubes	
	Cylinders	
	Standard Tensile Cylinder Shapes	
	Standard Block Shapes	
	Standard Beam Shapes	
	Standard Kerb Shapes	
	Standard Flag Shapes	
	Standard Brick Shapes	
	Standard Channel Shapes	
	Standard Aggregate Sizes	
	Sample Types and Sizes: Accu-Tek Range to ASTM C39/ C78M/C109	76
	Standard Cube Sizes	
	Standard Cylinder Shapes	
	Standard Block Shapes	
	Standard Beam Shapes	
<b>Appendix 2</b>	<b>Pace Rate Limits</b>	<b>77</b>
<b>Appendix 3</b>	<b>Printout Formats</b>	<b>77</b>
<b>Appendix 4</b>	<b>Results File Formats</b>	<b>78</b>
<b>Appendix 5</b>	<b>Glossary of Icons</b>	<b>81</b>
<b>Appendix 6</b>	<b>Troubleshooting Guide</b>	<b>83</b>
<b>Appendix 7</b>	<b>Menu Tree</b>	<b>85</b>
<b>Appendix 8</b>	<b>Error Codes</b>	<b>86</b>
<b>Appendix 9</b>	<b>ADR to ELE Logger P2P Connection</b>	<b>90</b>
	<b>EC Declaration of Conformity</b>	<b>95</b>
	<b>FCC Suppliers Declaration of Conformity</b>	<b>96</b>
	<b>Noise Test Certificate</b>	<b>97</b>
	WEEE Directive	102
<b>37-4860</b>	<b>BS Rectangular Platens</b>	
<b>37-5250</b>	<b>Self-centring Lower Platen</b>	
<b>37-6130</b>	<b>37-6140 100 kN Flexural Frames</b>	
<b>39-5600</b>	<b>Compression Frame Jig Assembly</b>	

## 1 Specification

Specifications are subject to change without notice.

Console Power Requirements	Compression tester: 115 VAC +/-10%, 60 Hz, 10 A 230 VAC +/-10%, 50/60 Hz, 5 A	
Console Dimensions (L x W x H)	480 x 400 x 1050 mm, 18.9" x 15.7" x 41.3"	
Console Weight	75 kg, 165 lb	
Operating Environment	Temperature: 0 to 40°C ( 32 to 104°F) Humidity: 10 to 90%, non-condensing Operating Altitude: 2000m maximum	
Storage Environment	Temperature: -20 to 70°C ( -4 to 158°F)	
Protection Class	I, IP20	
Pollution Degree/Installation Category	2: II	
Reservoir Capacity	12 L, 21 pt	
Hydraulic Oil Type	Shell Tellus T46 or equivalent oil to viscosity grade ISO HV46	
Dimensions, Weight and Frame Capacity	Refer to individual frame specification	
Vertical and Horizontal Clearance	Refer to individual frame specification	
Capacity and Measurement Range	Refer to individual frame specification	
Accuracy	Factory calibrated to $\pm 1\%$ of reading (Class 1)	
Repeatability	1% of reading	
Controller	ADR Touch™ Control PRO digital readout unit	
Pressure Transducer	Sensor 1 -	0 to 700 bar (0 to 10,152 psi) Output +0.05 to 10 V
	Sensor 2 -	0 to 70 Bar (0 to 1015 psi) Output +0.05 to 10V

## Safety Information

### NOTICE

The manufacturer is not responsible for any damage due to misapplication or misuse of this product including, without limitation, direct, incidental and consequential damages, and disclaims such damages to the full extent permitted under applicable law. The user is solely responsible to identify critical application risks and install appropriate mechanisms to protect processes during a possible equipment malfunction.

Please read this entire manual before unpacking, setting up or operating this equipment. Pay attention to all danger and caution statements. Failure to do so could result in serious injury to the operator or damage to the equipment. Make sure that the protection provided by this equipment is not impaired. Do not use or install this equipment in any manner other than that specified in this manual.

### NOTICE

**In areas where the power supply instability is an issue, it is recommended that an Uninterruptible Power Supply (UPS) is fitted to prevent possible damage to the machine and loss of recorded test data. In addition to the usual features of surge suppression and filtering, the UPS selected must provide voltage conditioning if it is suspected that the supply voltage may dip below the Nominal Voltage by more than 10%.**

## Use of Hazard Information

### DANGER

Indicates a potentially or imminently hazardous situation which, if not avoided, will result in death or serious injury.

### WARNING

Indicates a potentially or imminently hazardous situation which, if not avoided, could result in death or serious injury.

### CAUTION



Indicates a potentially hazardous situation that may result in minor or moderate injury.

### NOTICE

Indicates a situation which, if not avoided, may cause damage to the instrument. Information that requires special emphasis.

## Precautionary labels

Read all labels and tags attached to the instrument. Personal injury or damage to the instrument could occur if not observed. A symbol on the instrument is referenced in the manual with a precautionary statement.

	<p>Electrical equipment marked with this symbol may not be disposed of in European public disposal systems after 12 August of 2005. In conformity with European local and national regulations (EU Directive 2002/98/EC), European electrical equipment users must now return old or end-of-life equipment to the Producer for disposal at no charge to the user.</p> <p><b>Note:</b> For return for recycling, please contact the equipment producer or supplier for instructions on how to return end-of-life equipment, producer-supplied electrical accessories, and all auxiliary items for proper disposal.</p>
	<p>This symbol, if noted on the instrument, references the instruction manual for operation and/or safety information.</p>

## EU Radio Interference and Immunity Regulation:

Supporting test records reside with the manufacturer.

The equipment has been tested and found to comply with the following standards.

EN61326-1:2013 Electrical equipment for measurement, control and laboratory use -EMC requirements - Part 1: General requirements, Group 1, Class A equipment (emissions only) and Industrial Environment (immunity section only).

EN55011:2009 (+A1) Limits and methods of measurement of radio disturbance characteristics of industrial, scientific and medical (ISM) radio-frequency equipment, Group 1 Class A equipment.

EN61000-3-2:2014 Electromagnetic compatibility (EMC) - Part 3-2: Limits - Limits for harmonic current emissions (equipment input current  $\leq 16$ A per phase).

EN61000-3-3:2013 Electromagnetic compatibility (EMC) - Part 3-3: Limits - Limitation of voltage changes, voltage fluctuations and flicker in public low-voltage supply systems, for equipment with rated current  $< 16$ A per phase and not subject to conditional connection.





## Product Overview

The ADR Touch Control PRO range of compression machines are designed to test characteristics of concrete, cement and aggregate samples. Machines consist of a Console (power pack) and various Compression Frames.

These instructions are for machines with a Console serial number beginning with 1939, i.e. of the format 1939-X-XXXXX. The associated power base will have a serial number in the form 1937-X-XXXXX.

 <b>WARNING</b>	
Do not test any specimen material other than those explicitly listed in the Specifications of this manual.	

 <b>WARNING</b>	
	Personal injury hazard. Instruments or components are heavy. Use assistance to install or move.

 <b>DANGER</b>	
	Do not operate machine near open flame or other heat sources.

The ELE ADR Touch Control PRO range of machines has been developed to satisfy the requirements for consistent high throughput testing of concrete, cement and aggregate samples.

The automatic loading cycle is controlled by the closed loop micro-processor/ hydraulic system.











Operation of these machines is straightforward, requiring the operator to depress the 'RUN' key, after selecting sample size and loading rate. Standard data for a wide range of samples i.e. size, type, load rate, is programmed into the machine's memory. Custom samples can be created and stored for use and a 'Favourites' option allows quick access to frequently used samples. Remote operation of the test machine is also possible via the supplied ELE Logger software.

All control functions and display are built into the hydraulic power pack. The micro-processor runs a series of self-test routines to check the operation of the system. A serial output port and Ethernet port are built into the system enabling test data stored in the memory to be downloaded to a PC or to a database. Test data can also be sent to a suitable printer.

Test procedures can be selected and displayed in kN, lbf or kgf engineering units.

Full details of the ADR Touch Control PRO can be found in Section 5.

## Warnings

 <b>WARNING</b>	
The Console contains an over pressure release valve that should only be adjusted by qualified personnel.	
 <b>WARNING</b>	
	Contact with the hot surface of the pump motor within the Console may result in burns.
 <b>WARNING</b>	
If the noise emitted from the machine becomes unbearable to the user, then appropriate ear protection should be worn.	
 <b>WARNING</b>	
	Disconnect the Console from the main supply before accessing the machine's electrical circuitry.
 <b>WARNING</b>	
	Inappropriate use of the compression frames could result in a risk of crushing.
 <b>WARNING</b>	
	Rectangular platen assemblies mounted on compression frames present a pinch point if handled incorrectly.
 <b>CAUTION</b>	
It is recommended that appropriate PPE, safety footwear and eye protection be worn whilst operating concrete compression machines.	

## 2 Introduction

### 2.1 Compression Frames

All frames have a single acting up-stroking ram with overtravel protection to shut the machine down should maximum platen travel be reached. The ram/cylinder incorporates a low friction coaxial PTFE seal. An air bleed screw is fitted at the top of the ram.

	<b>250/25 kN</b>	<b>2000 kN Standard</b>	<b>2000 kN BS EN</b>	<b>3000 kN BS EN</b>
Overall Dimensions ( <i>length x width x height</i> )	355 x 455 x 1230 mm	440 x 364 x 1035 mm	440 x 536 x 1125 mm	630 x 510 x 1110 mm
Approximate Weight	100 kg	550 kg	750 kg	1270 kg
Maximum Vertical Clearance	205 mm	340 mm	340 mm	340 mm
Maximum Horizontal Clearance	25 kN : 160 mm 250 kN : 225 mm	320 mm	356 mm	310 mm
Upper Platen Dimensions	150 dia x 18 mm	222 dia x 30 mm	300 dia x 44 mm	300 dia x 44 mm
Lower Platen Dimensions	150 dia x 20 mm	222 dia x 25.5 mm	200 x 200 x 38 mm	200 x 200 x 38 mm
Maximum Ram Travel	15 mm	50 mm	50 mm	50 mm

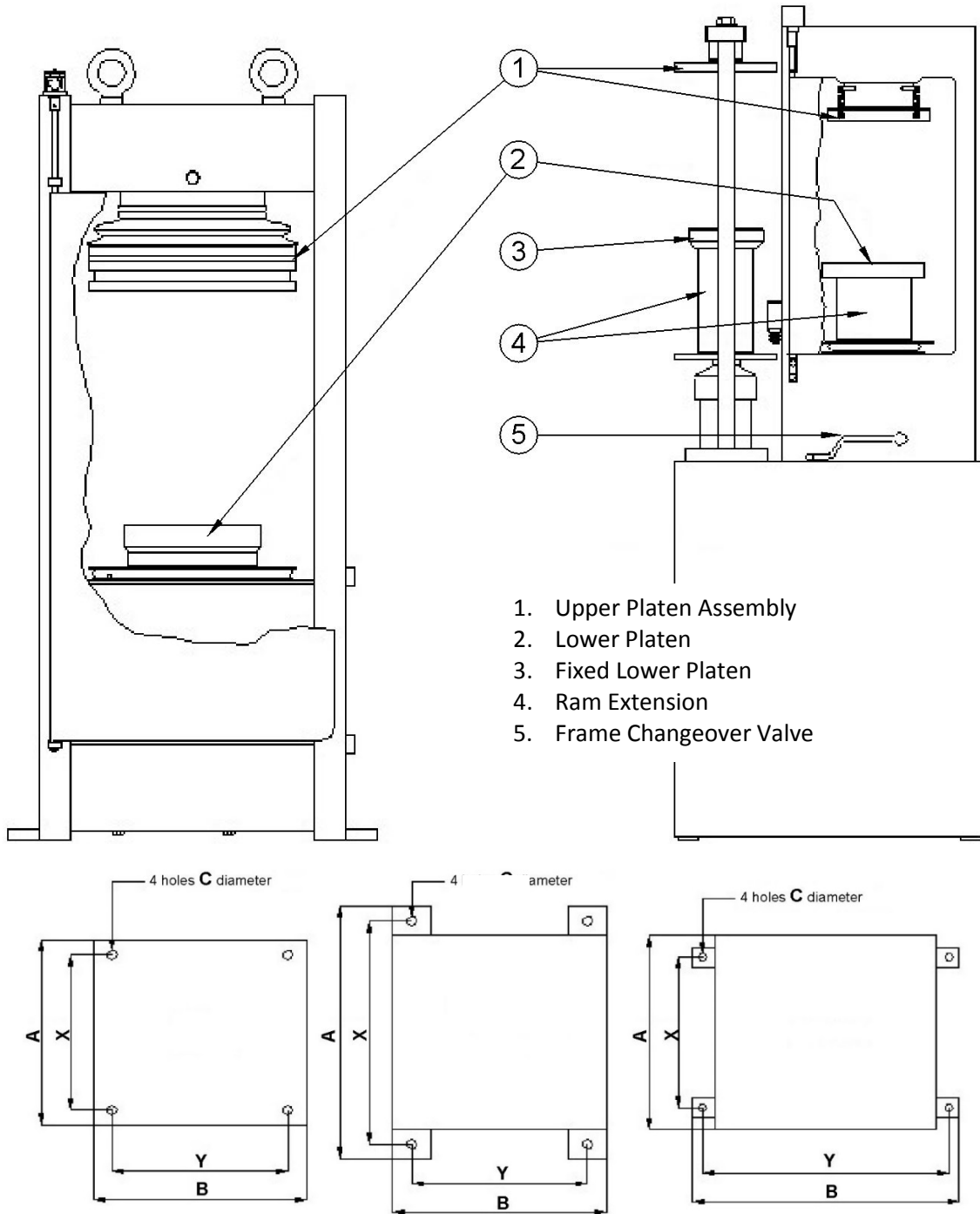

1. Upper Platen Assembly
2. Lower Platen
3. Fixed Lower Platen
4. Ram Extension
5. Frame Changeover Valve

Figure 1 : Upper View – Arrangement of Compression Frames  
 Lower View – Footprint Dimensions

Compression Frame	Dimension (mm)				
	A	B	C	X	Y
250/25	355	455	-	-	-
2000 Standard	440	364	13	410	308
2000 BS EN	440	536	20	310	496
3000 BS EN	630	510	20	570	410

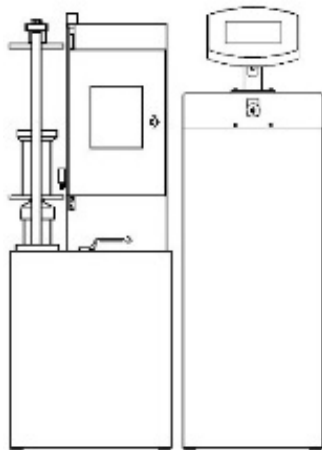

ADR Touch Control PRO  
250/25

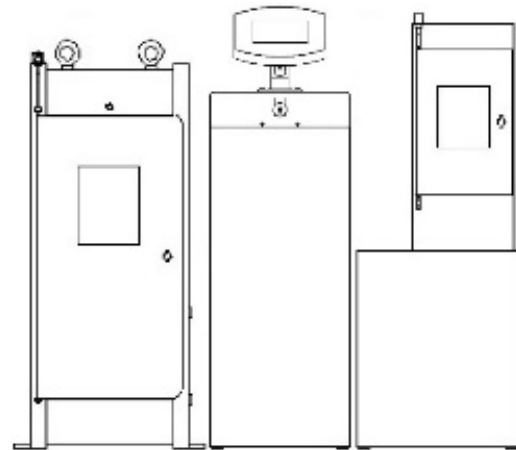

ADR Touch Control PRO  
BS EN 2000/250

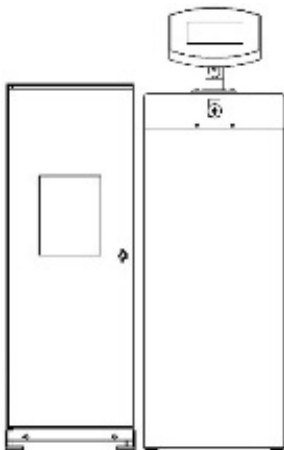

ADR Touch Control PRO  
2000 Standard

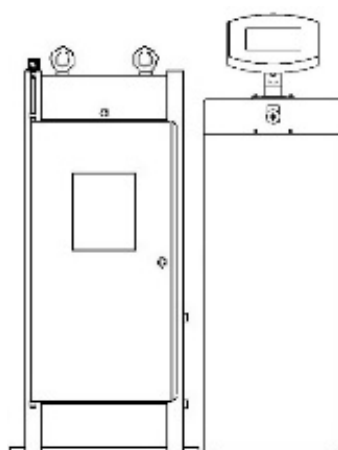

ADR Touch Control PRO  
2000 BS EN

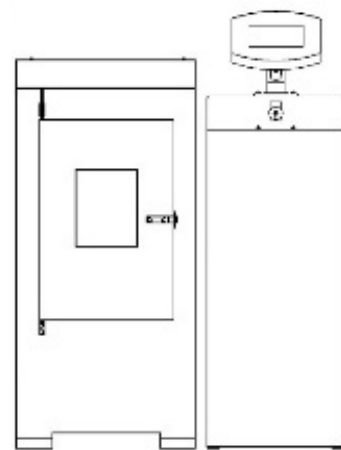

ADR Touch Control PRO  
3000 BS EN

Figure 2 : The ADR Touch Control PRO Range

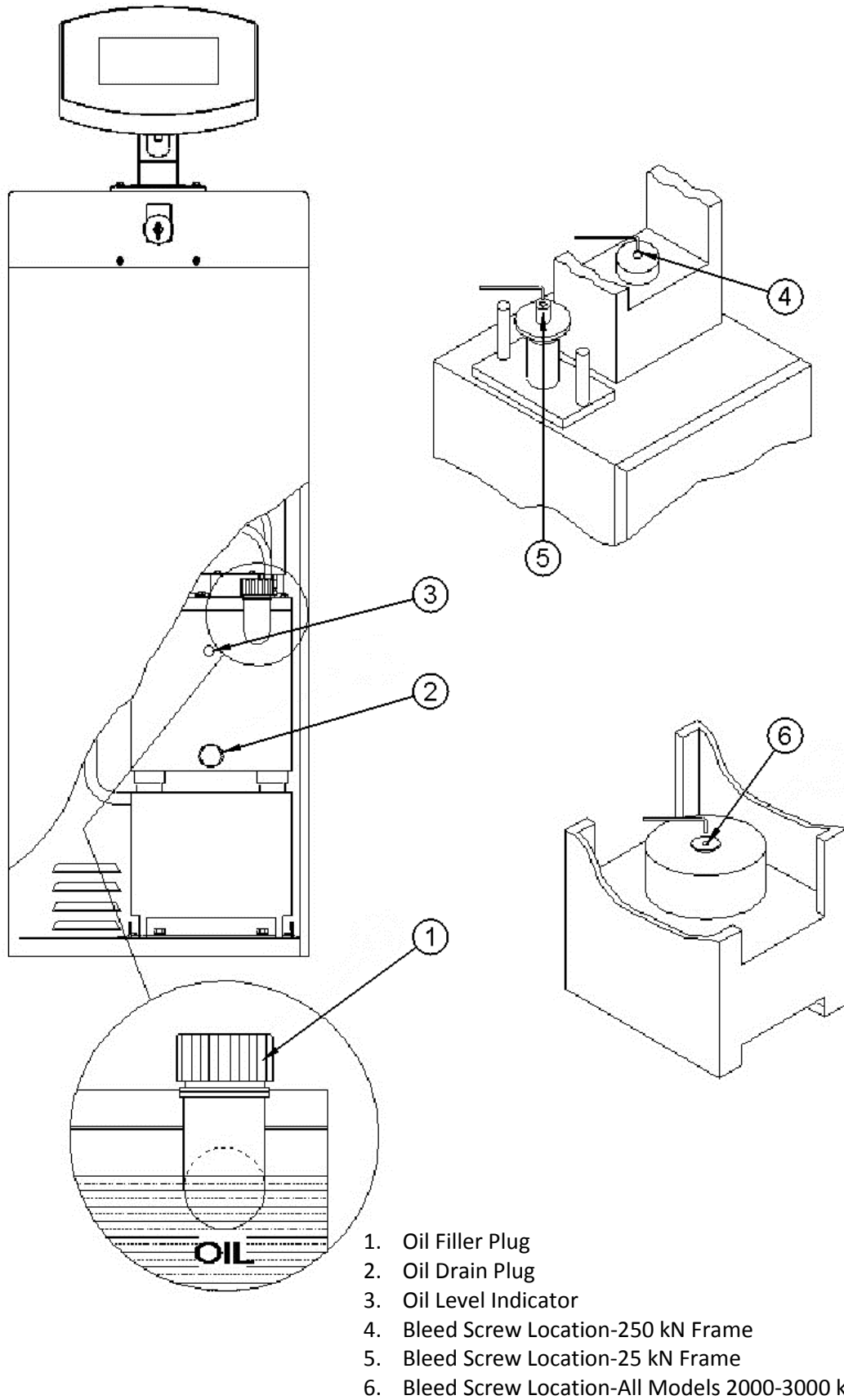

Figure 3 : Oil Filler & Bleed Screw Locations

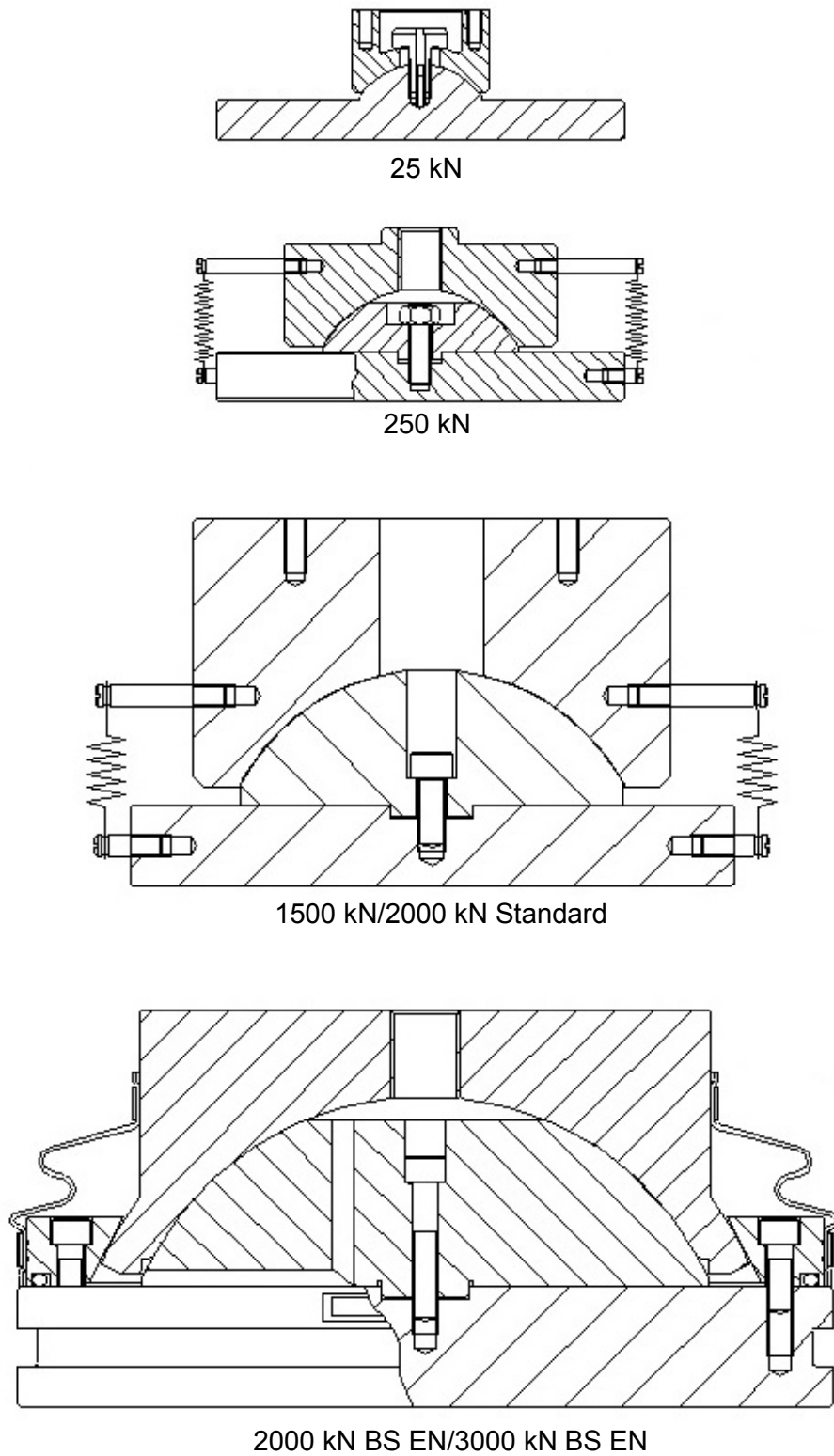

Figure 4 : Upper Platen Assemblies

## 2.2 Upper Platen Assemblies (see Figure 4)

Some models feature oil filled upper platen assemblies. The oil used is a special type only obtained from ELE International. The use of any other type of oil will impair performance.

## 2.3 Flexural and Transverse Frames

For operating instructions on the 100 kN Flexural Frames, part numbers 37-6130 and 37-6140, refer to the separate Operating Instruction document 9901X0098.

# 3 Installation

## 3.1 Moving, Lifting and Siting

### WARNING

Exercise extreme caution when lifting the machine. Use only approved and tested equipment. ELE International will accept no responsibility for damage caused by mishandling.

The ADR Touch Control PRO will be delivered in two main parts, both are mounted on pallets and should remain on the pallets until they have been moved as near as possible to their final position.

### WARNING

The final position of the machine should have its rear facing a wall with a gap of approximately 0.5m. The area behind the unit must not be used as a walkway, and is only for accessing the rear of the unit during any maintenance procedure.

### 3.1.1 Moving, Lifting and Siting the 250/25 Compression Frame

To remove from the pallet, unscrew the four bolts (accessed from underneath the pallet) which secure the pallet to the Compression Frame cabinet. The machine may then be lifted/moved away from the pallet and placed into position using a fork lift or hoist and lifting straps under the cabinet.

### 3.1.2 Moving, Lifting and Siting the 2000 kN and 3000 kN Compression Frames

To remove the Compression Frame from the pallet, unscrew the four securing bolts, then lift the Compression Frame away from the pallet.

The Compression Frame can be lifted by a fork lift or hoist and lifting straps. The forks can be positioned under the upper platen after removing the front gate and the rear screen. A flat piece of wood must be placed on the forks to prevent damage to the upper platen.

The 2000/3000 BS Compression Frames are also supplied with two “Dynamo” eyebolts which, if not supplied already fitted, can be screwed in the top of the frame through the large holes in the top cover.

### NOTICE

The eyebolts supplied are “Dynamo” eyebolts to BS4278 which are intended for direct lifting only. A spreader beam or spreader frame must always be used.

### 3.1.3 Moving, Lifting and Siting the Console

Lift/move away from the pallet and place into position using a fork lift or hoist and lifting straps under the cabinet.



### 3.2 Connecting the Compression Frame to the Console

#### 3.2.1 Connecting the Door Guard/Ram Travel Limit Switch

The ADR Touch Control PRO has two Door Guard/Ram travel limit IEC sockets so that two load frames can be connected.

#### NOTICE

The Door Guard/Ram travel limit connections are for connection to the adjacent compression frames. These outputs are not for connection to other equipment. The output is at 24V DC.

Ensure that the connectors from the frames are plugged in. Where only one frame is fitted, a dummy plug must be fitted in the unused socket.

### 3.3 Electrical Connections

#### **Electrical Safety**

#### ⚠ WARNING



Before removing any covers or performing maintenance repair and service, isolate from electrical supply by removing mains plug. Where mains supply is required during these activities, only competent persons should perform the work.  
Check that the power supply is compatible with the requirements stated on the label and connect in accordance with IEE regulations or to local requirements.

#### **UK Connections**

This machine may be operated through a standard 13A socket outlet when fitted with an appropriate 3 pin plug fused in accordance with the label.

#### **Note: Connect cable to plug as follows:**

Brown wire	L	Live or Power
Blue wire	N	Neutral
Green/Yellow wire	E	Earth or Ground

#### **Portable Appliance Tests (PAT)**

All ELE designed products are tested for electrical safety prior to sale.

An electrical safety test label is fitted (usually adjacent to the mains input socket).

Should no label be found, please contact ELE Service Department quoting the serial number of the equipment.

Organisations have an obligation to ensure equipment is maintained and is safe for use. Regular PAT testing is one means of ensuring equipment continues to be electrically safe.

#### NOTICE

Important: do not connect PAT leads to sensitive components such as PCBs, control switches, etc.  
**DO NOT FLASH TEST ELECTRONIC EQUIPMENT.**

Use the earth stud (M5 screw head) on the rear of the Console Head or an external earth connection). Contact ELE's Service Department for assistance.

### 3.3.1 Emergency Stop

The ADR Touch Control PRO is fitted with a lockout E-Stop button. When this button is operated, the pumps and dump valve are shut down and all pressure in the machine is reduced to zero. This provides a means of quickly shutting down the machine.

The ADR Touch Control PRO can be operated remotely and for this reason the lockout E-Stop provides the operator with a means of securing the console, so that no operations can be carried out whilst maintenance or servicing is in progress.

The lockout E-Stop is supplied with a key which is required to reset the button.

### 3.3.2 Connecting the Hydraulics

Connect the outlet of the Console (at the rear) to the inlet of the Compression Frame (at the rear) with the flexible hydraulic hose supplied, ensuring that all connections are fully tightened.

### 3.4 Preparing the Hydraulics (see Figure 3)

The hydraulic reservoir in the Console is normally full when the machine is delivered. If the reservoir is empty on delivery, the oil will be supplied in containers.

#### 3.4.1 Checking the Oil Level (see Figure 3)

To check the oil level, open the Console using the quick release twist screws at the top of the front panel. The oil level should be greater than half full as viewed on the oil sight gauge. Older style lower Consoles without a sight gauge have their oil level checked by opening the oil filler plug and confirming that oil is visible at the bottom of the thread in the filler elbow.

If oil is required, use only the grade as specified in Section 1.

#### 3.4.2 Bleeding the Hydraulic System (see Figures 1 and 3)

The hydraulic ram is provided with a bleed screw. This is used to release any air from the hydraulic system after installation or after an oil change. To open or close the bleed screw requires the use of a 5 mm AF hexagon wrench (supplied with the machine).

#### NOTICE

The bleed screw captivates a steel ball. Do not completely remove the bleed screw as this may cause the ball to become lost.

The bleed screw on the ADR Touch Control PRO 2000 and 3000 Compression Frame is accessible after removing the lower platen (and any distance pieces).

The bleed screw on the ADR Touch Control PRO 250 Compression Frame is accessible after lifting off the lower platen (and any distance pieces), unscrewing the 4 screws now visible and then removing the ram extension.

The bleed screw on the 25 kN Frame is accessible after unscrewing the grub screw in the side of the ram extension and then by removing the ram extension together with the fixed lower platen still attached to it.

#### 3.4.2.1 Operate the Console (refer to Figure 3) to provide a flow of oil to the Compression Frame and unscrew the bleed screw no more than four turns. Air and oil will escape from the bleed screw. When the oil is free from air bubbles, close the bleed screw and tighten firmly. The hydraulic ram should now rise.

**⚠ WARNING**

If the Compression Frame has a front gate with safety interlock, this must be bypassed before the Console pump will operate. This must only be performed by appropriately trained service personnel and the bypass must be removed once the bleeding process has been completed.

3.4.2.2 If an additional loading frame or Flexural Frame is fitted then repeat 3.4.2.1 but using the bleed screw on the other Frame.

**Note: Remember to change the Operating Mode (refer to Section 5.1) when bleeding additional frames.**

### 3.5 Distance Pieces

Since the maximum platen travel on a 2000 and 3000 kN Compression Frame is 50 mm, the vertical clearance between the upper and lower platen should be adjusted using distance pieces, according to the specimen being tested. The distance pieces are located on the ram spigot and then the lower platen is placed on top of the distance pieces, located by the spigot.

Ensure that all mating surfaces between the ram, distance piece(s) and platen are free from concrete debris etc. before assembling these items.

These machines are supplied with a 20 mm distance piece ready for testing 300 x 150 mm diameter cylinders.

**Note: The distance pieces must NOT be used on top of the platen.**

**Recommended Distance Pieces for Cement & Mortar testing for 39-6155 machines**

Sample Size	Distance pieces required	
40 X 40mm *	EL39-6210	EL39-6220
50 X 50mm	EL39-6210	EL39-6220
70 X 70mm	EL39-6215	EL39-6220
100 X 100mm	EL39-6220	-

\* When not using compression Jig EL39-5600

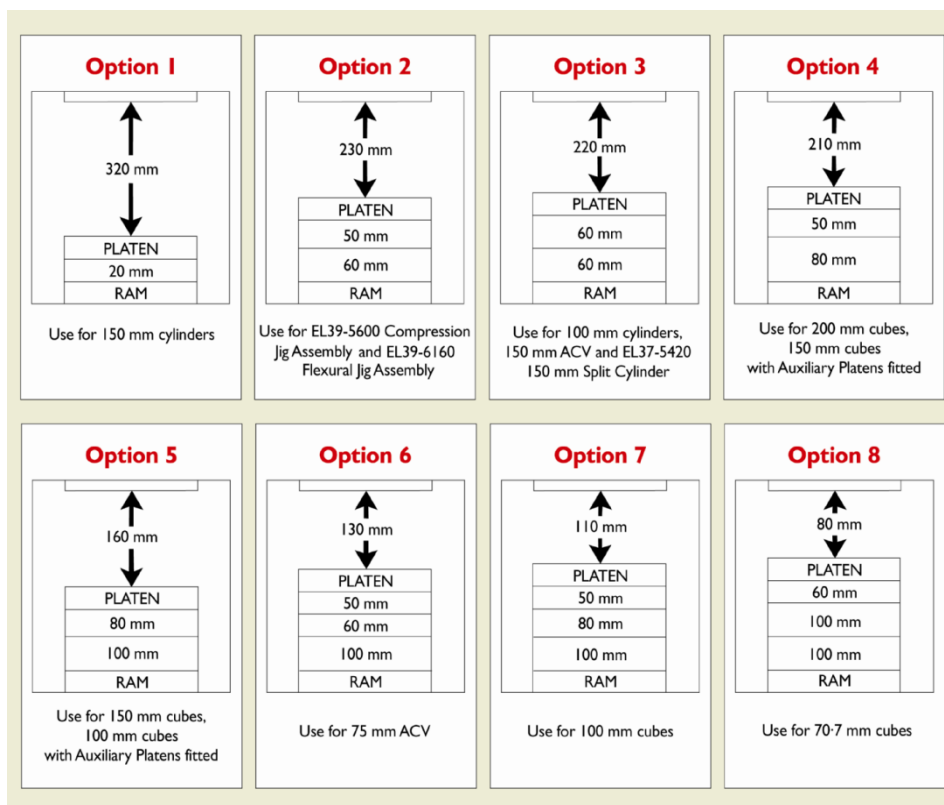

**Safety**

Whilst the test is in operation do not remove any covers or attempt to adjust any part of the machine.

Ensure all moving parts are thoroughly secured before attempting any maintenance.

Ensure all appropriate measures are taken to protect the operator from excessive noise.

See Noise Certificate (when supplied).

## 4 ADR Touch Control PRO Console

### 4.1 Foreword

These instructions refer to ADR Touch Control PRO machines fitted with:  
Firmware version VX.XX.XX

The firmware is the control software which is permanently resident in the machine.

Please contact the ELE Service Department for information on our firmware updating service.

### 4.2 Turning the ADR Touch Control PRO On

Switch on using the mains switch adjacent to the mains inlet cable. When the ADR Touch Control PRO is turned on, the system performs self-checks and then updates the measurement system. During this time, the following message is displayed:

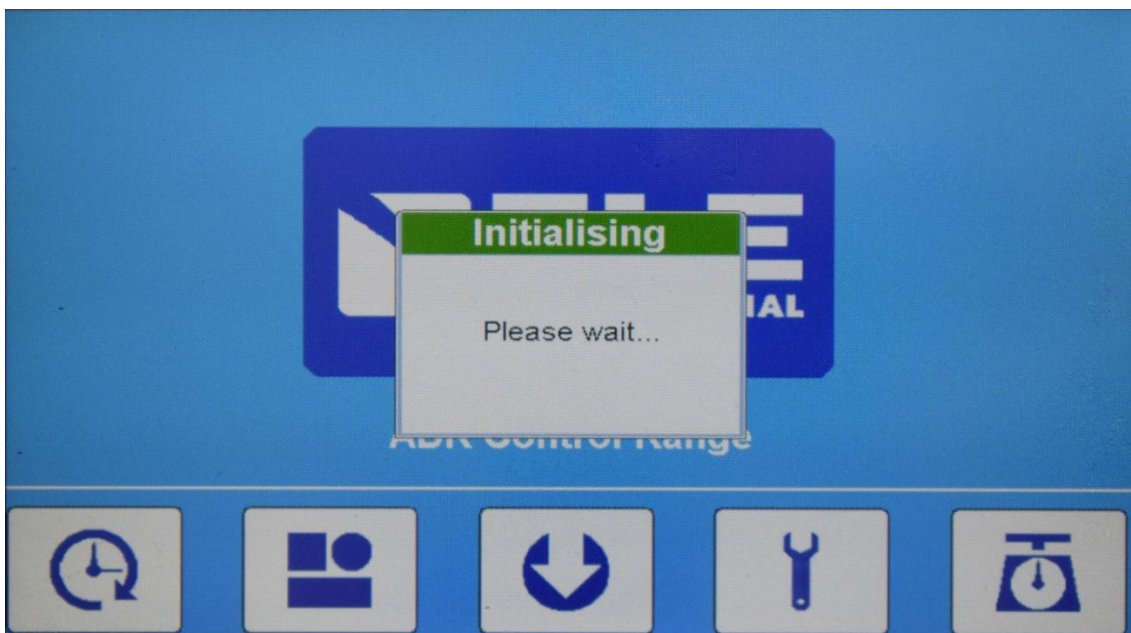

#### 4.2.1 Initial Display

After system checks and updates have been completed, the screen display will be of the form:

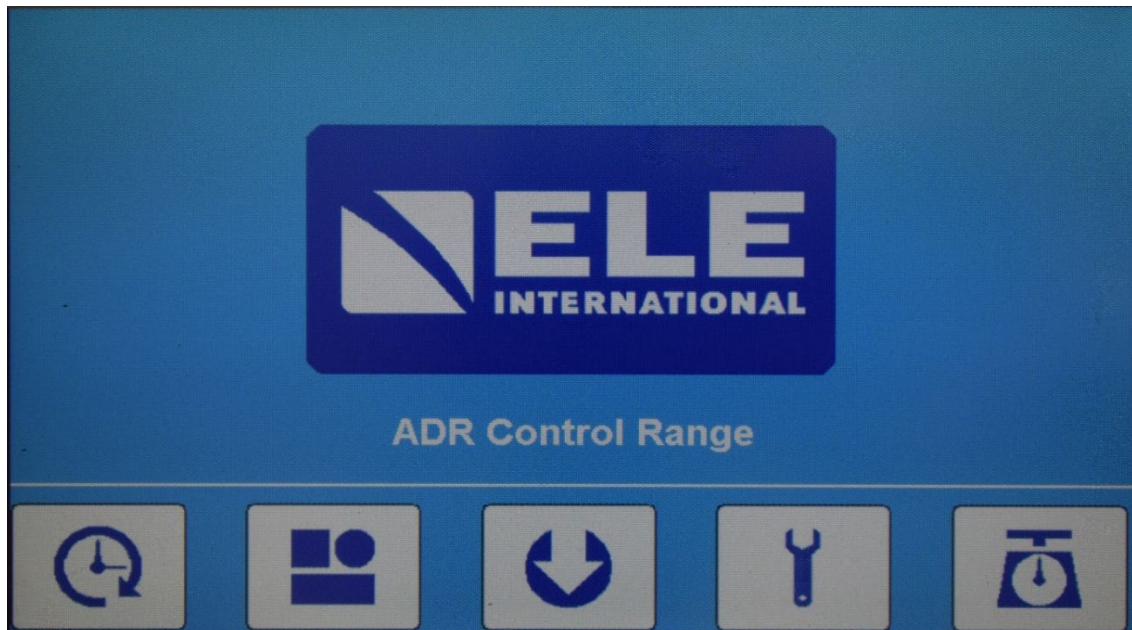

This is the main system **Home Screen** display and is always shown after the system checks and updates have been performed.

**Note: The ADR Touch Control PRO stores the system configuration internally so any changes that are made are not lost when the power is removed.**

#### 4.3 Front Panel Display and Controls

All the operations of the ADR Touch Control PRO are controlled from the 7.0" Touch screen display.

##### 4.3.1 Display





The 7.0" display has a bright, easy to read character set and function icons which can be seen under all internal lighting conditions. The head itself can rotate through 75° and tilt up to 45° allowing the operator to maintain visual contact with the screen from a variety of positions. When a test is running, the display switches to a large character mode so that the load measurement can be seen at a distance.

#### NOTICE

Do not use excessive force when pressing the touch screen panel.

#### 4.3.2 Home Screen Keys

There are 5 short cut function icons that are used to control the operation of the system.

	Select Sample Types
	Saved Data Screen
	Settings Screen
	Calibration Menu
	Test Start Menu

#### 4.3.3 Touch Screen Brightness Setting

The Touch Screen Brightness can be adjusted, within allowable limits. From the Initial screen, press the Settings icon. Select **User-Defined Settings>Adjust Display**. Press the + or – buttons to adjust the brightness accordingly.

The system will automatically save the new brightness setting in non-volatile memory.

#### 4.3.4 Key Click Beeper

From the Adjust Display menu, the Key Click beeper can be switched on or off. Check the box marked Key Click to hear the beeper when a key is pressed.

#### 4.3.5 General Settings

General display settings and test units can be changed by selecting the **Settings** icon



from the Initial screen.

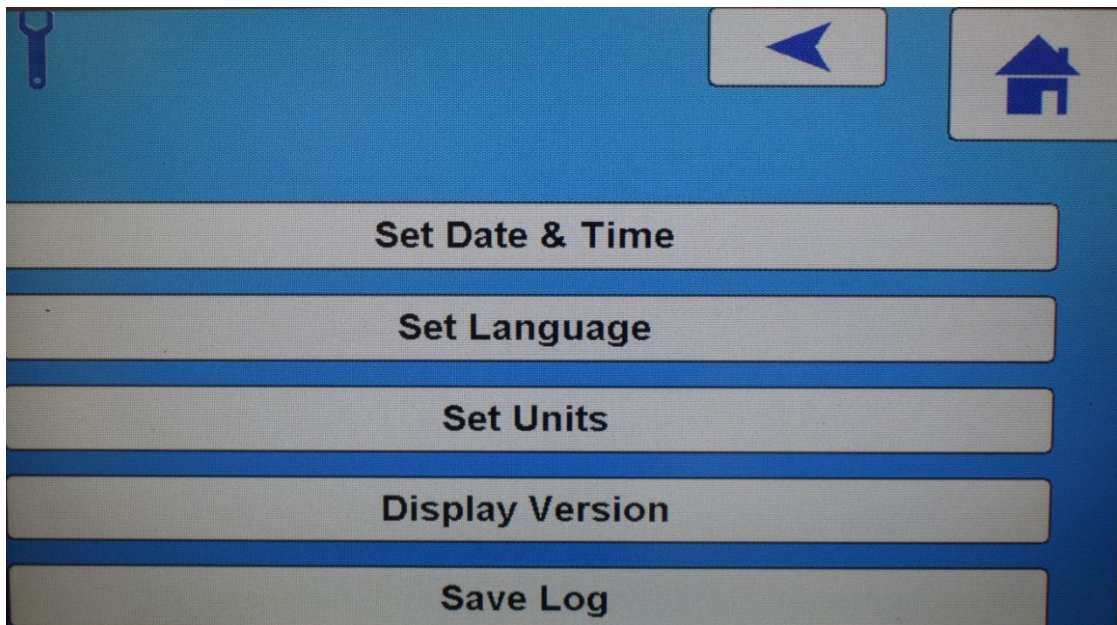

##### 4.3.5.1 Setting the Time and Date

To set the date and time, select **Set Date & Time** and use the various + and - buttons to adjust to the format shown on the screen.

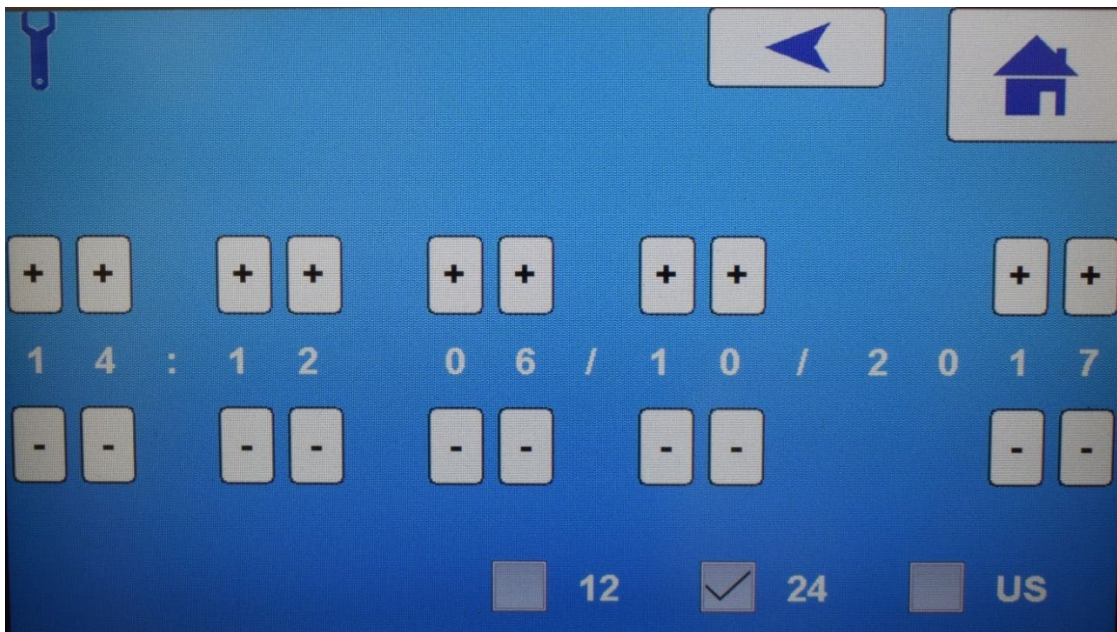

The time can be displayed in 12 or 24 hour format. Selecting the US format box will change the date format to MM/DD/YYYY.



#### 4.3.5.2 Setting the Language

The operating language can be changed by selecting **Set Language** and choosing from one of the pre-programmed language options available:

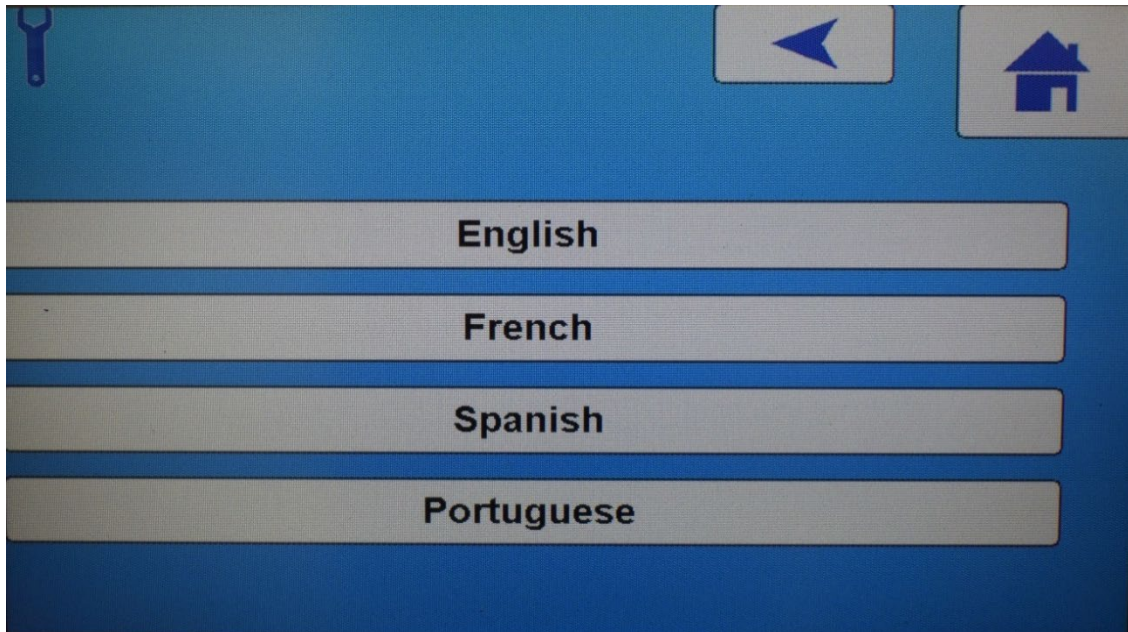

#### 4.3.5.3 Display Units

The display units selected define the units in which the load is displayed, and which units are used for pace rate, sample dimensions, sample weight and sample density. The following table shows the available section.

Units	Load	Pace	Dimensions	Weight	Density	Stress
<b>SI</b>	kN	kN/sec	mm	g	kg/m <sup>3</sup>	N/mm <sup>2</sup>
<b>Imperial</b>	lbf	lbf/sec	ins	lb	lbf/ft <sup>3</sup>	lbs/in <sup>2</sup>
<b>Metric</b>	kgf	kgf/sec	cm	g	g/cm <sup>3</sup>	kgs/cm <sup>2</sup>

The default setting for the display units is S.I. To change this press **Set Units** and select the required units.

A set of default values for the sample pace rates and failure parameters are loaded into the ADR Touch Control PRO's memory. These values will be displayed in the units selected for testing. When different test units are selected, the values of each parameter will automatically convert to be correct for the selected test units. See Appendix 1 for default values.

**Note : Some default sample sizes are not available in all three Set Unit options.**

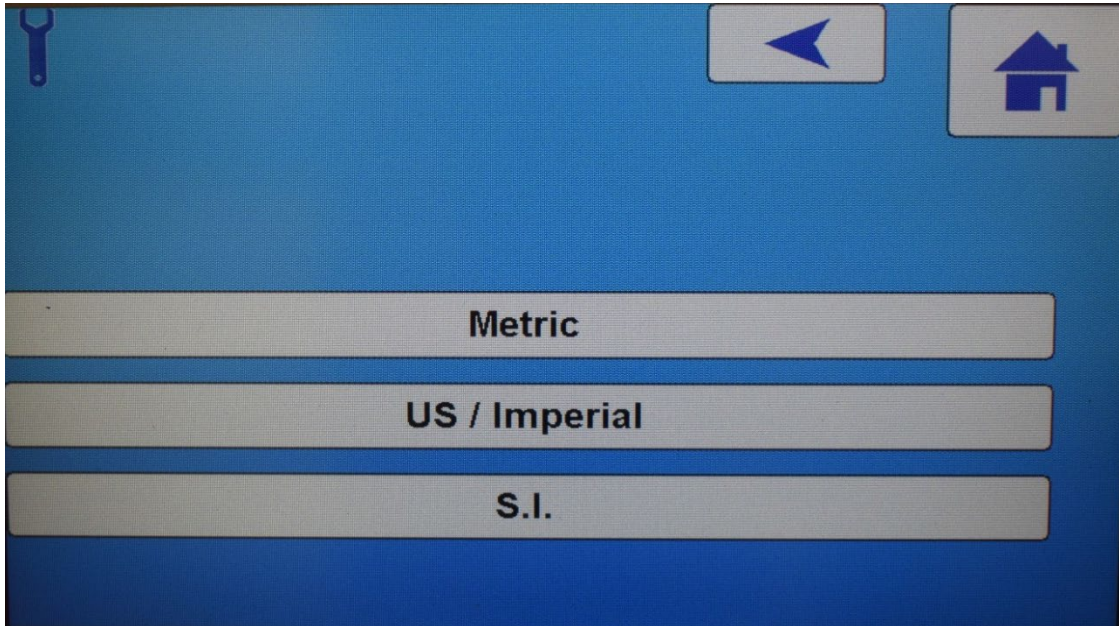

#### 4.3.5.4 Display Version

The Display Version will show the current version of the firmware running in the display head.

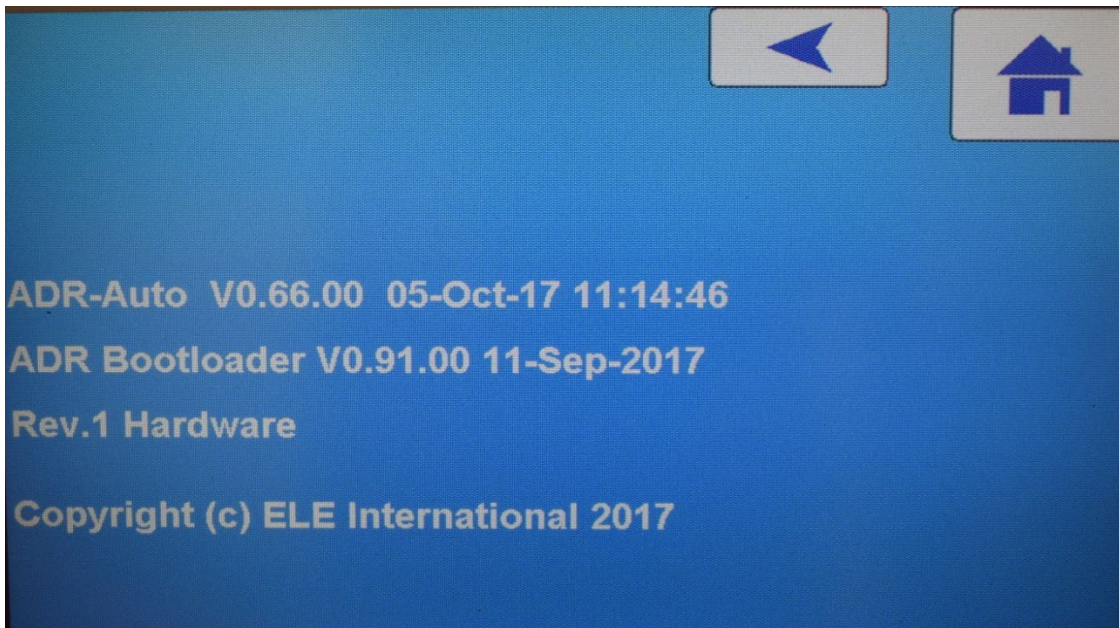

#### 4.3.5.5 Save Log

Used for diagnostic purposes under the direction of ELE International.

#### 4.4 ADR Touch Control PRO Measurement Modes

The ADR Touch Control PRO has various operating modes. For systems fitted with one frame, the ADR Touch Control PRO operates in Mode 1 only. When fitted with two frames, Mode 1 is used for one of the frames, and Mode 2 for the other. Mode 1B is used when the Dual Sensor option has been fitted, allowing high accuracy testing of low strength samples in a 2000 kN load frame. The current operating mode and its associated frame type (eg.2000 kN Compression) is shown in the RUN Screen display.

For systems with an automatic change-over valve, the ADR Touch Control PRO retains the selected mode when it is turned off, and restores that mode when it is turned on again.

#### 4.5 Configuring the ADR Touch Control PRO's Operating Modes

Before running a test, check that the current operating mode is the required one, and that the mode has been configured correctly. The operating mode is selected and configured by pressing the **Settings** icon, then **Select Mode and Pace**.

The screen display will be of the form:

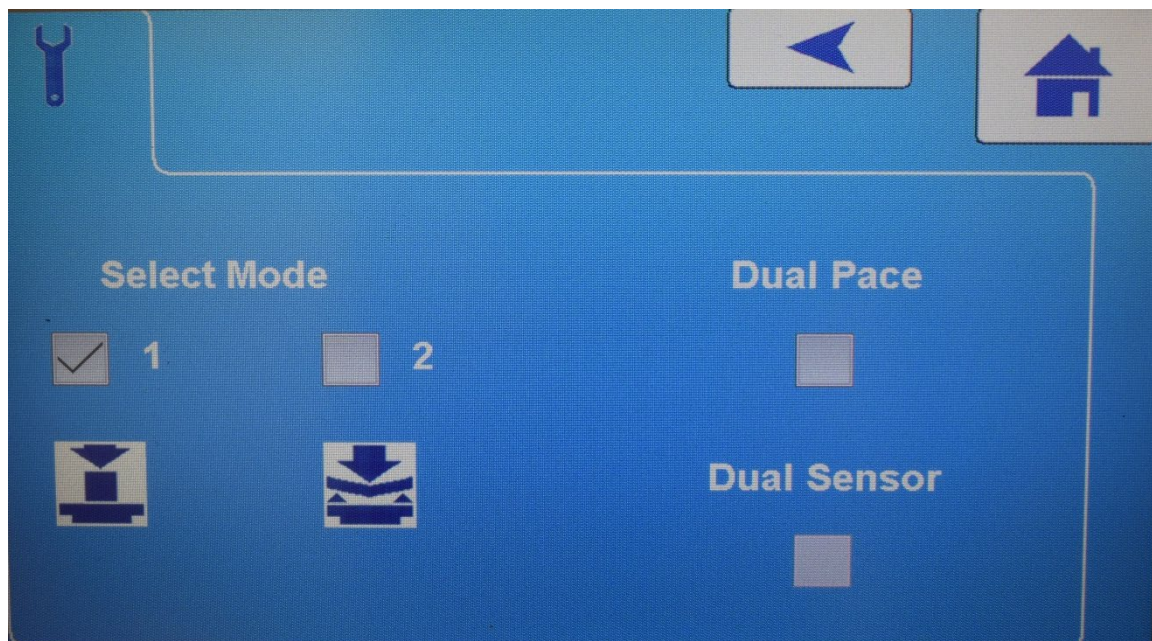

Press the relevant button(s) to select the option required, and then press the **Home**

 icon to return to the **Initial Screen**.

When the Dual Sensor option is checked, the frame mode will be set to 1B to allow for compression testing of low strength samples in a high capacity frame.

#### 4.5.1 Selecting the Operating Mode

When two separate frames are attached, the ADR Touch Control PRO 2000 and 3000 are fitted with a solenoid operated changeover valve inside the Console, which is used to connect the hydraulic power pack to the required frame. If only one frame is attached, this valve is not fitted.

The ADR Touch Control PRO 250/25 has a manual frame changeover valve fitted externally (refer to Figure 1).

To change from one frame to the other, press the desired “**Select Mode**” button as shown in the above picture.

Do not attempt to operate the changeover valve until the ram on the currently selected frame has returned to its initial position. If a manual changeover valve is fitted, it must be operated manually.

#### NOTICE

Note that any options set apply to the currently selected operating mode. **Change to the required mode before setting the options.**

##### 4.5.1.1 Dual Pace

It is possible to select two sample loading Pace rates when conducting tests by checking the box marked Dual Pace. This will allow the operator to input an Initial Rate and a Final Rate. A Transition Load, the point at which the pace changes from the Initial to the Final is also set. This is done in the Test Setup screen. See Section 4.5.4.6.

##### 4.5.1.2 Dual Sensor

An optional second sensor can be fitted to the ADR Touch Control PRO to allow for high-accuracy testing of low strength samples in the larger capacity frames. To use this option the Dual Sensor box must be checked. When the Dual Sensor box is selected, the Operating Mode will be set to 1B. In this mode, it is possible to test low-strength samples, typically cement cubes or prisms, in the high-strength 2000 kN frame. A removable compression jig may be required for some sample sizes.

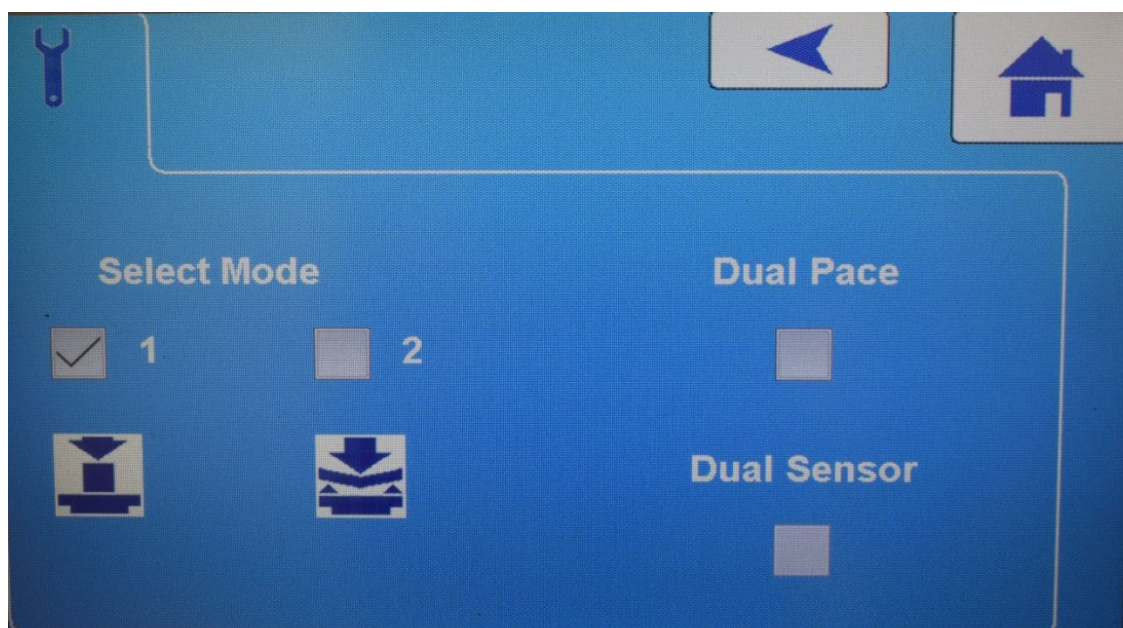

#### 4.5.2 Defining the Operating Mode Options

There are several options which affect the operation of the ADR Touch Control PRO. To set these, press the **Settings Icon** and select the **Sample Failure Settings** option. The screen display will be of the form:

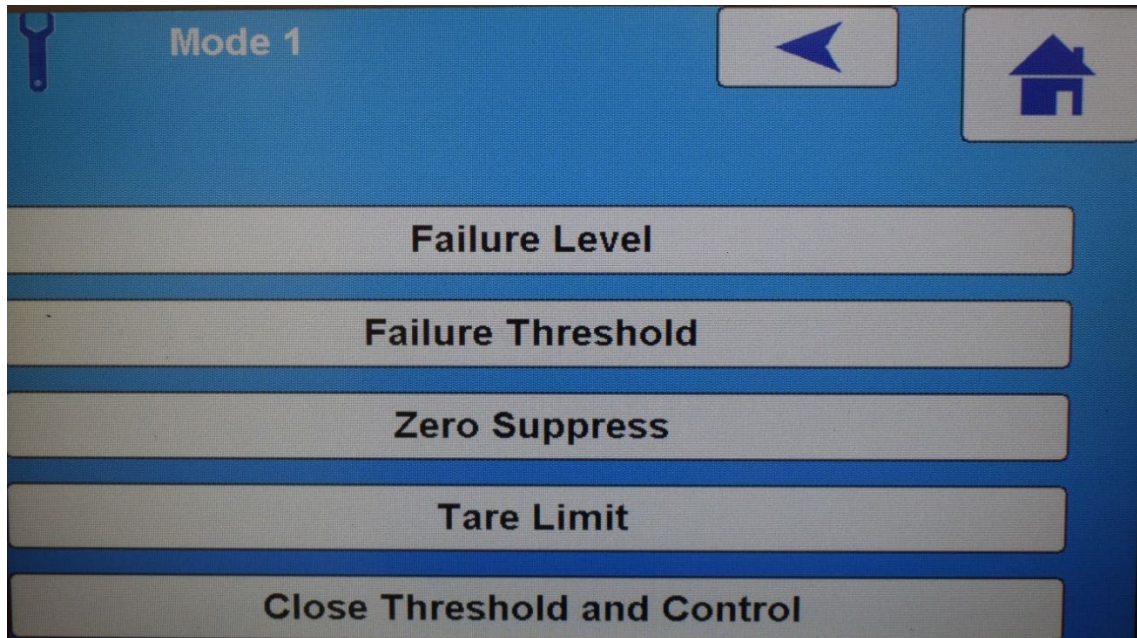

To select any of the **Sample Failure Settings** options, press the appropriate button to select the required option field. If a numeric change is required, clear the existing value using the X button and then change the value using the Numeric Keyboard and select **Enter**. The display will now return to the previous screen. The options are described below.

##### 4.5.2.1 Failure Level

The ADR Touch Control PRO detects a sample failure by measuring the peak load sustained by the sample and waiting until the load has fallen by a defined percentage of this peak load. Use the numeric keypad to change the default value. Increasing the percentage means that the ADR Touch Control PRO continues to try to maintain the loading rate for a longer time as the sample fails. Decreasing the percentage value will speed up the cycle time very slightly but could mean that small fluctuations in the load early in the test cycle may be seen as failures, when they are not.

#### 4.5.2.2 Failure Threshold

The definition of the Failure Threshold parameter depends on the form of pace control selected, and if either the ACV (Aggregate Crushing Value) or TFV (Ten Percent Fines Value) sample test modes have been selected. The parameter is always entered as a load in the units defined for display. The following describes each form of pace control and how the Failure Threshold is used.

##### **Automatic**

When automatic pace control is selected, the Failure Threshold parameter defines the load at which the ADR Touch Control PRO starts looking for a failure. The machine ignores any drops in load that exceed the Failure Level below this Threshold. The Failure Threshold should be increased if the sample under test can exhibit a false failure early in the loading cycle, as can happen when testing bricks capped with plywood.

If an ACV or TFV test has been selected when selecting the sample type, the Failure Threshold has a different meaning. The ADR Touch Control PRO stops pacing when the load attains the level set in the Failure Threshold parameter.

**Note: The ADR Touch Control PRO sets a default pace rate and threshold for ACV tests, but these values must be entered by the user for TFV tests.**

##### **Board**

In Board mode, the Failure Threshold is as described for Automatic pace control.

To update the Failure Threshold displayed, clear the existing value using the X button, enter a new load using the numeric keypad and then press the **Ent** key. If the **Ent** key is not pressed, the value will not be updated. For instructions on setting Automatic or Board control see Section 4.5.2.5.

#### 4.5.2.3 Zero Suppression

The ADR Touch Control PRO displays a load value of zero until the load exceeds the value in the Zero Suppression Range entry. Use the numeric keypad to change the default value. Set the value to zero if this facility is not required.

#### 4.5.2.4 Tare Limit

Defines the limit below which a Tare of the displayed load can be performed. To change this limit, clear the existing value with the X button and use the numeric buttons to enter a new value. Press the **Enter** icon to store the new value. This parameter has maximum values dependent on frame size.

#### 4.5.2.5 Close Threshold and Control

The ADR Touch Control PRO does not control the pace rate until the Close Threshold is exceeded. To change this limit, clear the existing value with the X button and use the numeric buttons to enter a new value. Press the **Enter** icon to store the new value.

The ADR Touch Control PRO can control the pace rate in two ways as follows:

##### **Automatic**

The ADR Touch Control PRO controls the pace rate automatically at the rate set. The automatic pace control operates from the Close Threshold until the sample fails. The load is then automatically removed and the peak load measurement displayed.

### **Board**

Board mode control is intended for use when testing blocks with fibre board capping. Maximum load is applied at the start of the test to compress the fibre board and the ADR Touch Control PRO does not initially control the pace rate. When the average pace rate measured over the previous 1 second is 90% of the set rate, the ADR Touch Control PRO then starts to control the pace rate. The point at which the ADR Touch Control PRO starts to control the pace rate will depend on the type of fibre board being used.

#### 4.5.3 User-Defined Settings

##### 4.5.3.1 Folder for Tests

Allows the user to define the name of the folder where test results are stored. Up to 8 characters can be used in the folder name. The default folder name is “**TESTS**” and this will contain sub-folders in date order. Test results are labelled with a reference number and time. There is a 512 number limit to the number of folders that can be created, however the display will only show the folder which is active at that time. For a full list of all available folders the ADR Touch Control PRO can be connected to a PC or laptop via the USB connection and viewed as a Removable Memory Device, or connected via the Ethernet port and viewed through the ELE Logger Application.

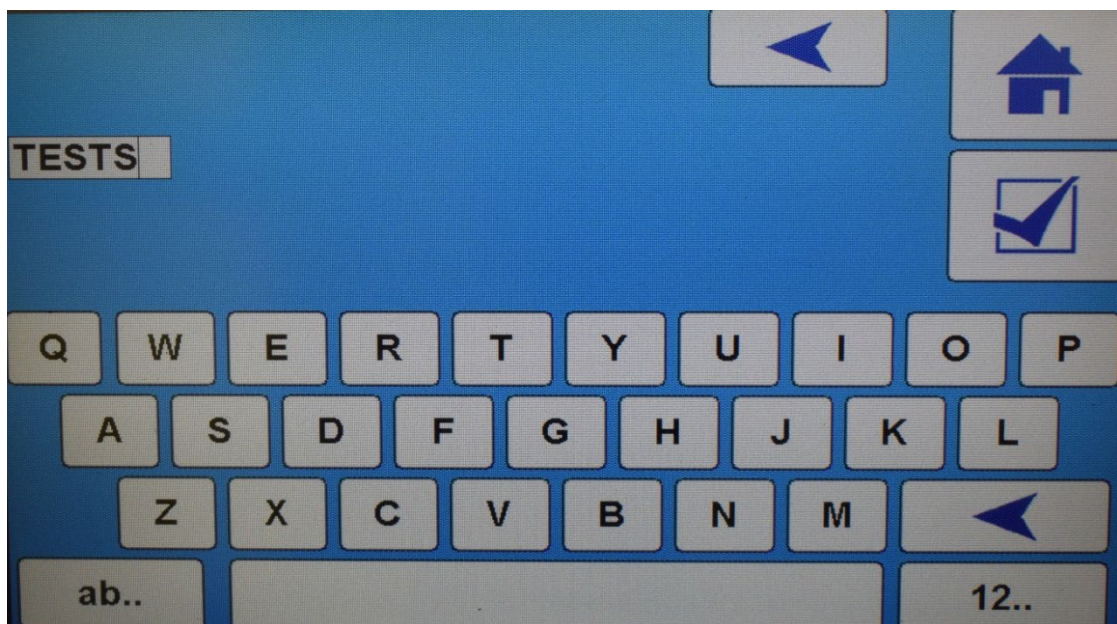

##### 4.5.3.2 Test Data Settings

Shows the options for the user to automatically save and print the sample test results and to enable an incremental reference number for each sample.

When the **Save Sample** box is checked, the test results will automatically be saved to the active test folder. The ADR Touch Control PRO can hold thousands of individual test result records. These records can be examined or downloaded via the Ethernet connection to a computer. When the memory is full, a diagnostic message ‘MEMORY FULL’ will appear on the screen to prompt the user to take action. The sampling frequency for the logging of test data is fixed at 4 Hz.

When the **Print Sample** box is checked, the test result will automatically be sent to an optional serial printer via an RS232 port, which can be connected directly to the display head. The test result is printed at the end of each test cycle. This port can also be connected to a LIMS application to record the test results locally.

When the **Increment Reference** box is checked, the sample reference will automatically be increased by a numerical value of 1 for each new test started. This reference number is used to label the saved test result folder.

Any active errors within the system are displayed on this screen, along with a button to reset and clear the logged fault. System Errors should be investigated and cleared before a new test cycle is started.

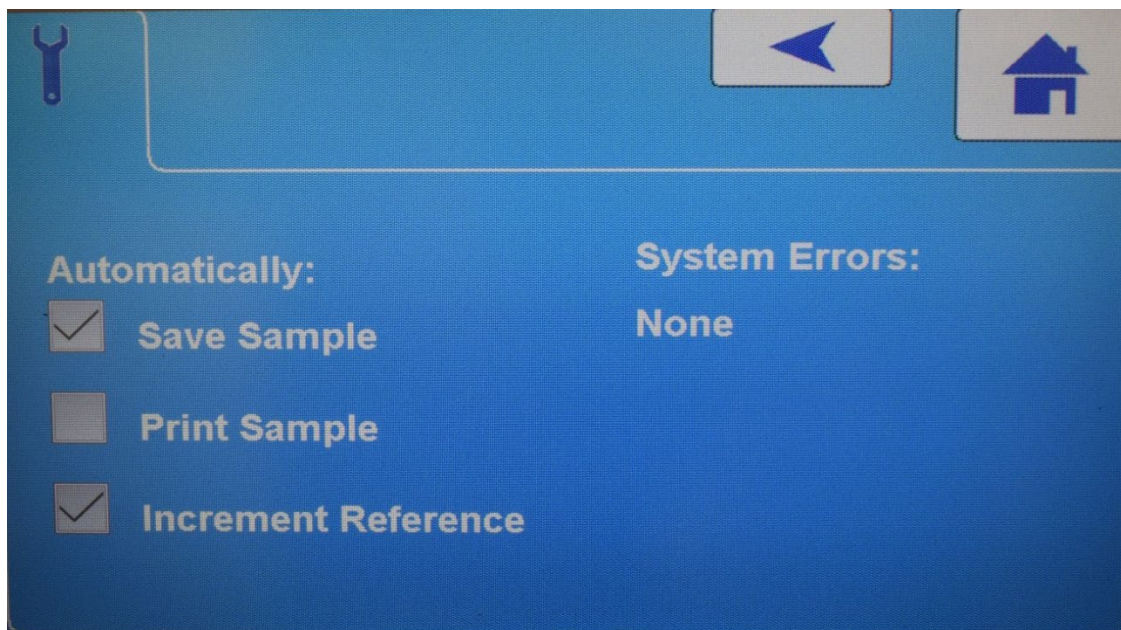

#### NOTICE

Once system errors are cleared it is necessary to power cycle the machine before further tests can be made.

#### 4.5.3.3 Pace Bar Width

The Pace Bar Width is displayed as a percentage of the desired pace rate. At 10% of the load frame capacity, two markers will appear on the pace bar, these indicate a tolerance for the loading rate during the test. The default setting for the pace rate width is 20% and this will show a marker at +10% and -10% of the desired loading rate, providing a visual reference for the loading control.

#### 4.5.3.4 Comms Port Settings

Settings for the output of data through the serial port can be viewed and altered. The assigned IP address of the ADR Touch Control PRO can be set for when connection to a Local Area Network via an Ethernet is required. By checking the box **Auto IP Address**, the ADR becomes discoverable on the network. See Sections 5.3 and 5.4 for details of setting up the remote connection.



#### 4.5.3.5 Verify Mode

Verify mode gives the user the ability to run the machine manually without automatic pace rate control. It is most commonly used for checking and validating the ADR Touch Control PRO's calibration data.

The main motor, rapid approach pump and control valve position can all be altered by the user from the touch screen, or from an optional manual override controller (accessory part number **1676B0070**).



**Note: The rapid approach pump button has to be continuously held in order for the pump to be powered.**

#### 4.5.4 Selecting the Sample Type and Size

Having selected the operating mode and set up any options required, the sample type and size should be selected. The ADR Touch Control PRO has a large database of predefined sample types and sizes, and Appendix 1 lists those available along with their associated pace rates.

**Note: The included sample sizes and associated pace rates are based on the latest standards information available. Any changes/updates may affect these default values and users should regularly check which is the current standard publication. If the sample under test is not in the database, the required pace rate and sample dimensions can be entered manually before the test is run.**

**Note: The number of sizes and dimensions depend on the display units selected, the display units (eg. kN) must be selected prior to choosing the sample type and size.**

#### 4.5.4.1 Sample Types

To choose a sample type, press the **Sample Type icon** and then choose from the options available. The screen displays will be of the form:



#### 4.5.4.2 Sample Sizes

Having selected the required sample type, the screen display will be of the form:

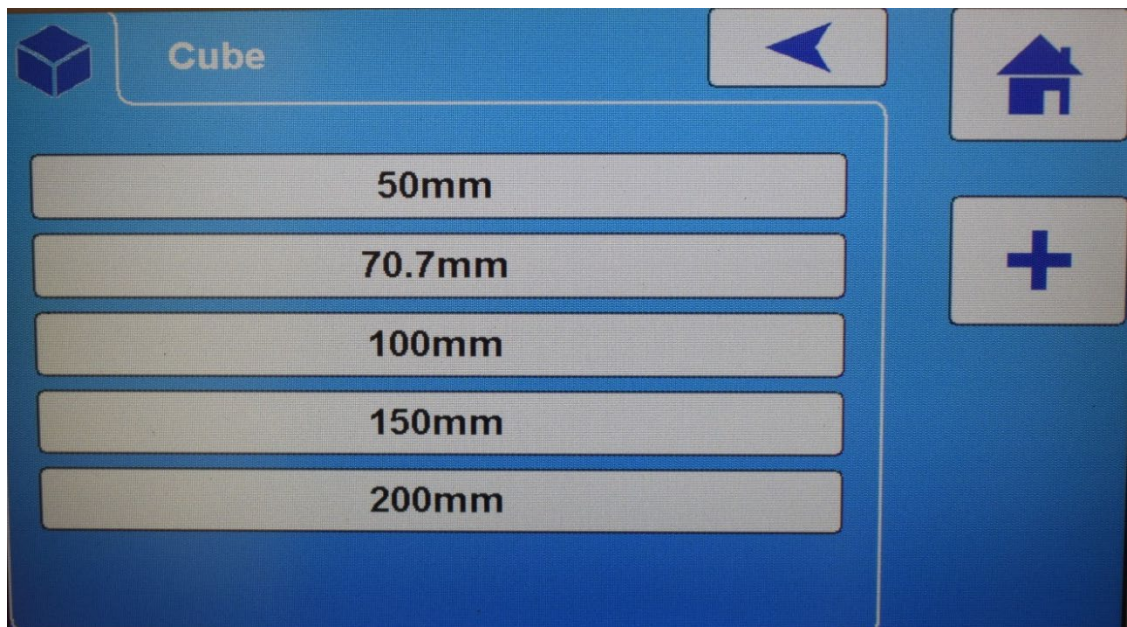

**Note:** See Appendix 1 for standard sizes available.

When the sample size has been selected, the screen will display the default Pace Rate and Reference values:

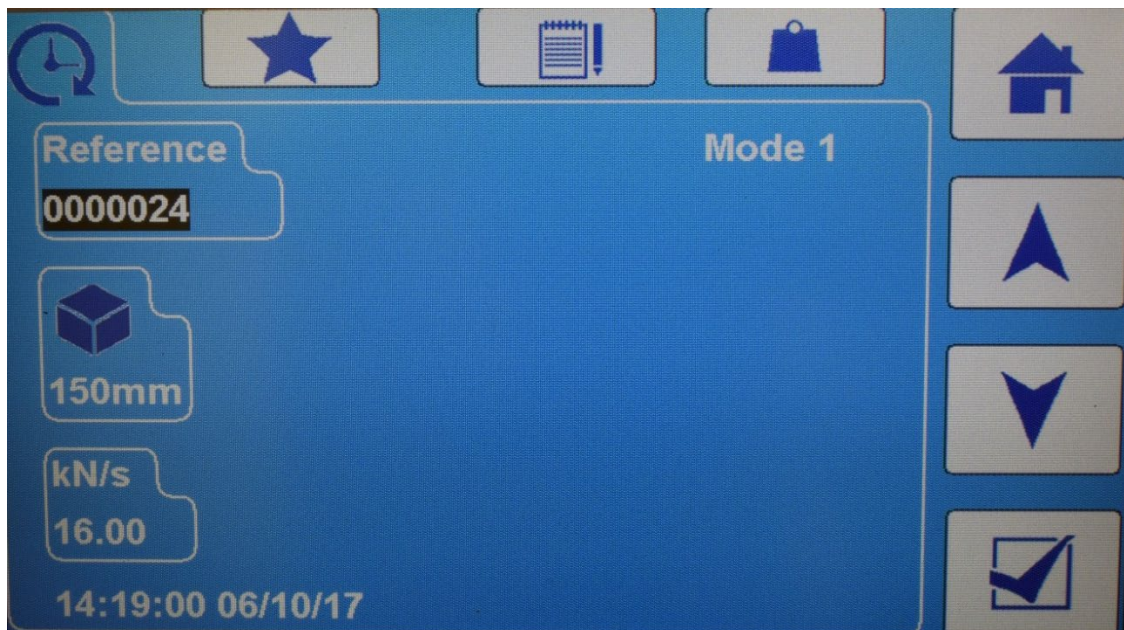

#### 4.5.4.3 Sample Favourites Option

Frequently used and custom samples can be stored as a 'Favourite' on the Initial Screen and can then be selected for use, quickly and easily, without the need for navigating through selection menus. This is done by selecting the **Favourite**

 icon from the sample setup screen. If any sample parameters need to be altered, this should be done before selecting the Favourite icon.

Up to 6 Favourite samples can be stored on the Initial Screen per mode.

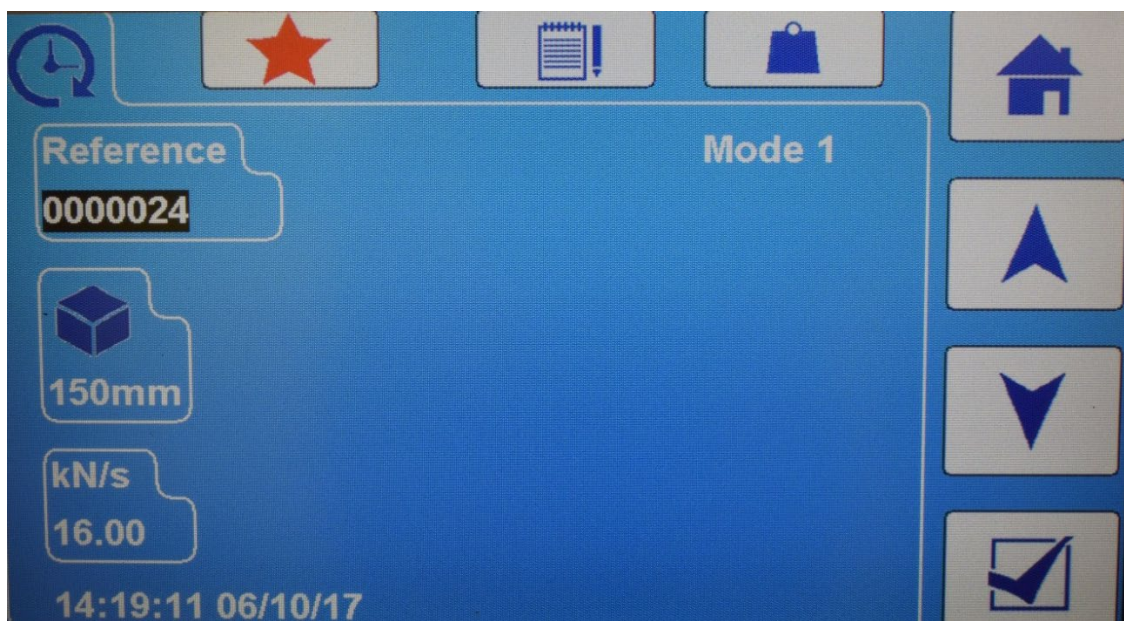

Sample Favourite option selected, and below, shown on Initial screen:

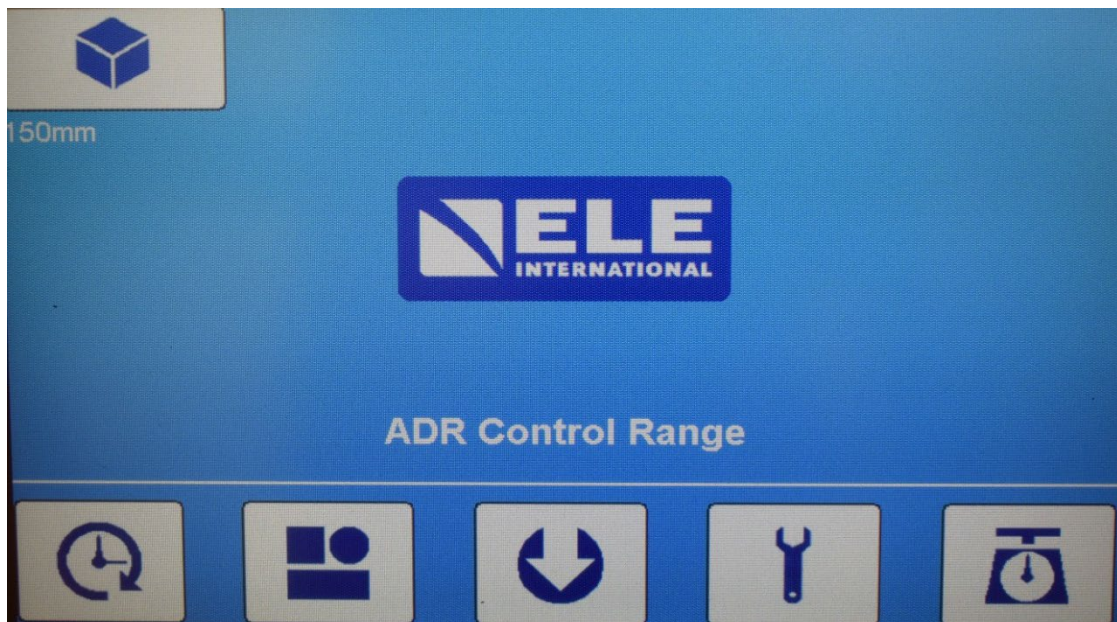

#### 4.5.4.4 Editing Values

Use the Up and Down arrows to select the fields for the Sample Reference, Sample Size and Pace Rate. These values can then be altered by pressing the **Edit** icon, clearing the existing value using the X button and entering a new value using the numerical buttons.

**Note: The default Pace Rates have been selected for their compliance to current test standards. Always consult the appropriate test standard before changing the Pace Rate values.**

#### 4.5.4.5 Editing Sample Size

Use the Up and Down arrows to select the sample size field and press the **Edit** icon to change the value. The value shown in the upper field is the Sample Title and will not affect calculations by being altered. The value shown in the lower field is the Sample Size and this value will be used in stress and density calculations.

**Note: For cubes, only one dimension is shown for editing, for other sample types, multiple dimensions can be edited.**

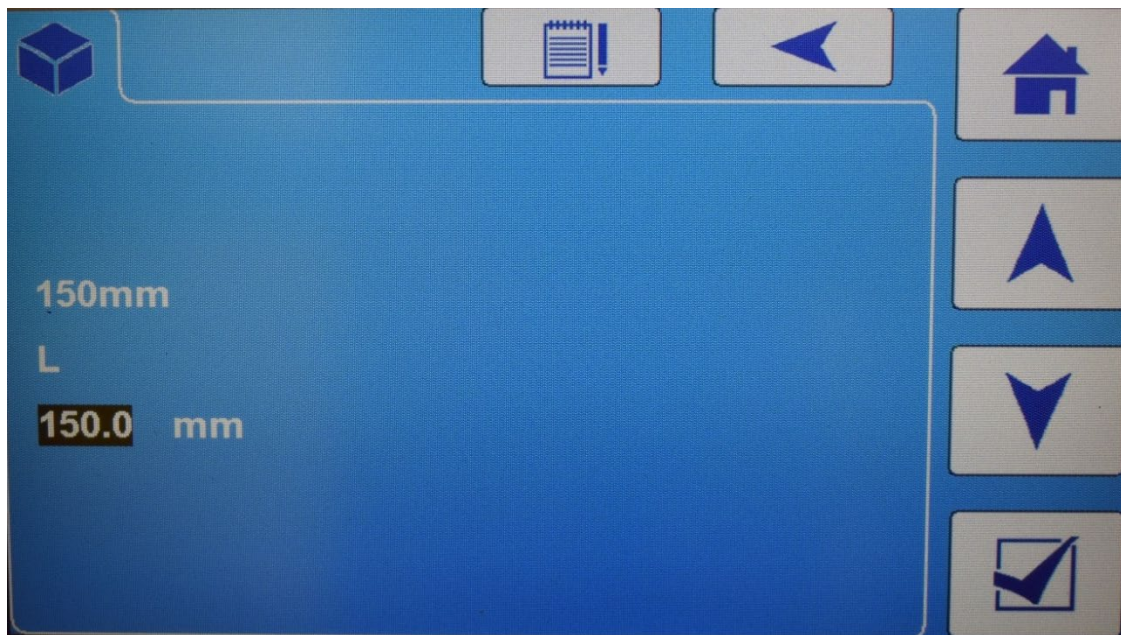

Custom sample sizes can be created by selecting the **Add** icon  which can be found on each of the specific Sample Type screens.

Using the **Edit** icon and the Up and Down arrows, set the title and dimension(s) for the new sample and press Enter. Scroll down to the Pace Rate field and set this to the desired value.

The custom setting should be saved as a Favourite if it is likely to be used again. This will create an icon on the Initial Screen which, when selected, will shortcut the setup menus and go straight to the Test Start screen.

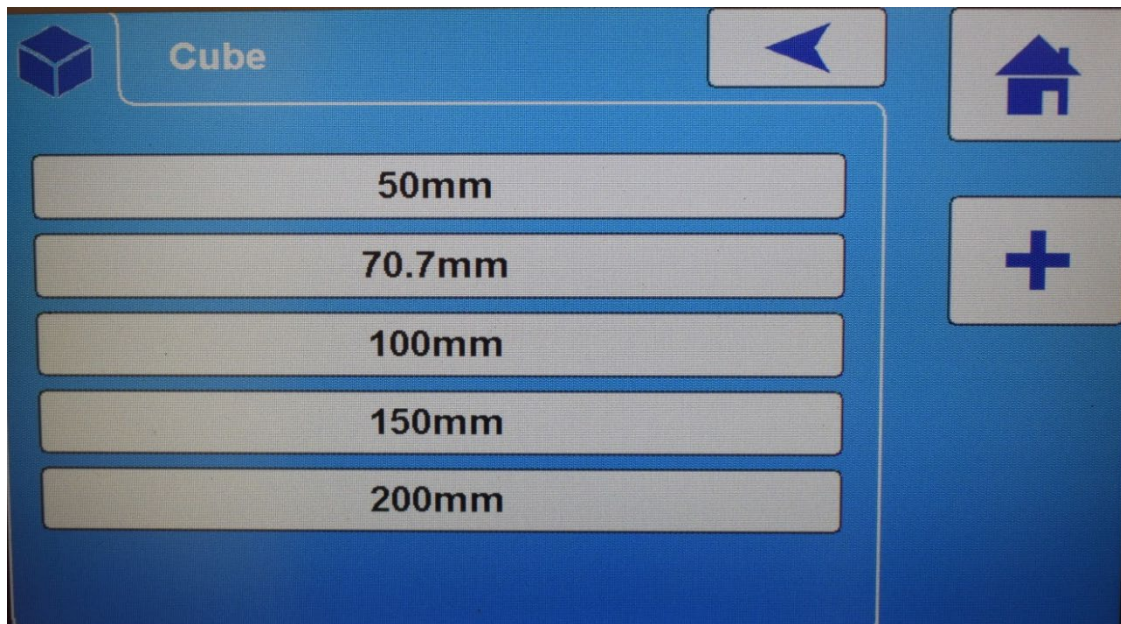

#### 4.5.4.6 Editing the Pace Rate

The ADR Touch Control PRO can be configured for dual pace rates. In dual rate mode, the ADR Touch Control PRO will control the pace rate at the first entered rate until a set Transition Load value is reached, and then continue pacing at the second rate. This option applies to the 2000 kN and 3000 kN compression frames. If dual rates are required, select the **Dual Pace** button in the **Settings** menu. The second pace rate must be within the frame limits or may be 0 if it is required that the load be held at the Transition Load without an increase. If the second pace rate is 0, there is an option to enter the time in seconds that the load will be held for. If nothing is entered, the test will run until the sample fails, a test time limit of 3600s (1 hour) or if the user halts the test manually.

**Note: There are default pace rate values which are set when the sample type is selected. These can be changed if required. See Section 4.6.2.**

The Pace Rate can be changed during the test cycle by pressing the **Edit** icon and entering the new Pace Rate required. This facility is available even if the Dual Pace option has not been selected.

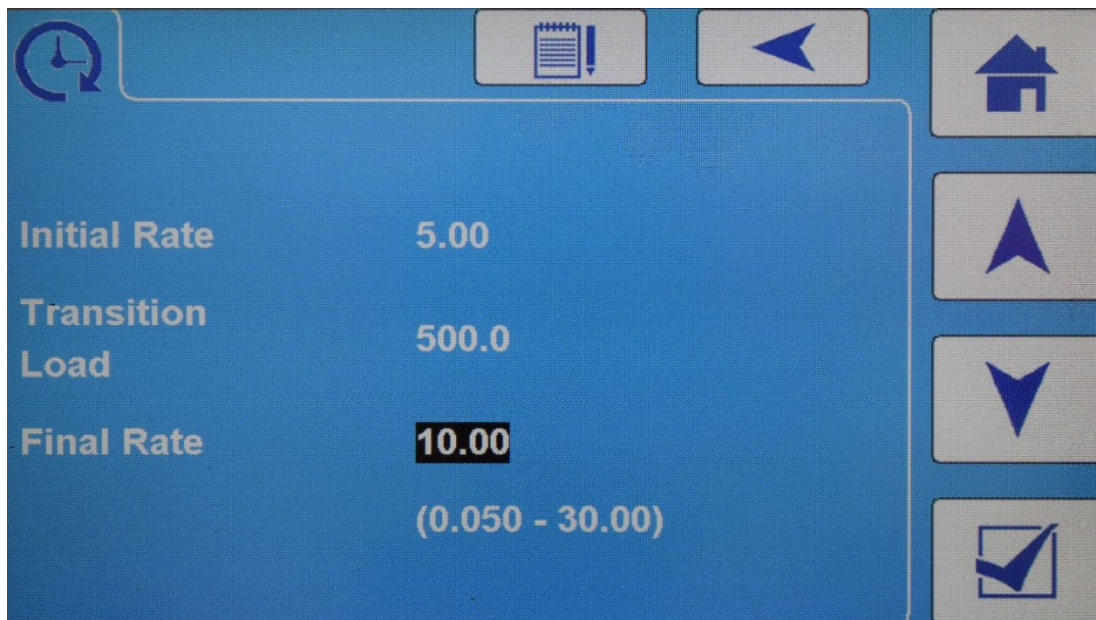

#### 4.5.4.7 Sample Density Values

Where relative densities are required, the weight of the sample in air and water can be entered. When the **Weight** icon  is selected from the Sample Setup screen, the user will be prompted to enter the Weight in Air and Weight in Water of the sample. This is done by clearing the original value using the X button, entering a new value using the numerical buttons and pressing Enter. Once a value for the Weight in Air has been entered, the screen with the Weight in Water field will appear. These values are used in the calculation of sample density and will be displayed in the test results.



#### 4.5.5 Default Settings

	Mode 1	Mode 2
Sample Reference	0000001	0000001
Display Units	SI	SI
Control	Automatic	Automatic
Auto Log	On	On
Auto Print	Off	Off
Auto-Increment	On	On
Dual Pace Rate	Off	Off
Dual Sensor	Off	Off
Failure Threshold	50 kN	5.0 kN
Failure Level	15%	15%
Zero Suppression	5.0 kN	0.3 kN
Close Threshold	7.0 kN	1.0 kN

#### 4.6 Running a Test

A test can be initiated from the Test Start screen of the ADR Touch Control PRO, or from the ELE Logger software, which can be run from a Windows PC or laptop and used to remotely start, end and analyse data from a test. The ELE Logger will only be able to start a test if the ADR is at the Home or Results screens.

Check that the sample type and control mode are correct. If they are not, return to the Sample Type and Settings screens and set them as required. A sample that has previously been selected as a Favourite can be used by selecting the appropriate icon from the Home screen.

By pressing the Test Start icon,  the following example screen will be shown:

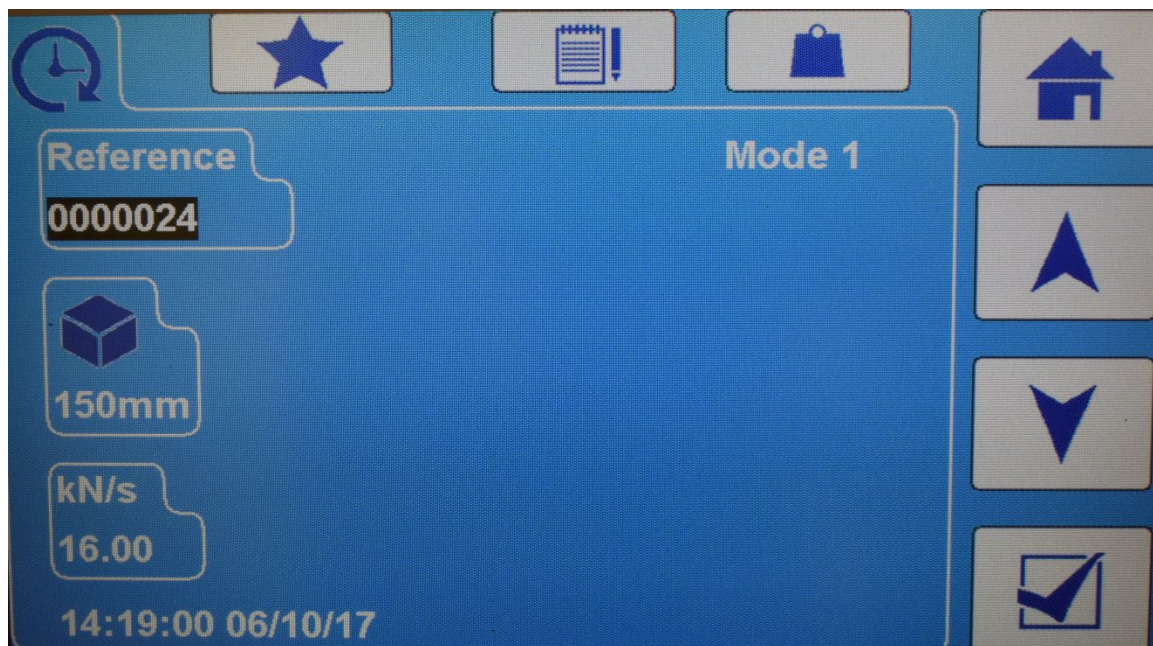

##### 4.6.1 Setting the Reference

The Reference is a 16 character, alpha-numerical value that is used to identify the sample in the test results. The reference will be used, along with the time, as the title of the folder in which the sample test result is stored. The reference can be altered at

the start of each test by using the  button to clear the data field and entering a new value with the displayed keyboard. If the Increment Reference box has been checked in the Settings menu, the reference value will automatically update by 1 each time a test is run. A blank reference can be entered if this facility is not used.

##### 4.6.2 Setting the Pace Rate

If the Pace Rate is not as required, enter the required pace rate or pace rates and transition load by pressing the **Edit** icon, clearing the data field with the X button, inputting the new value using the numeric buttons and pressing **Enter**. See Section 4.5.4.6 for further details.

The Pace Rate can be changed during the test cycle by pressing the **Edit** icon and entering the new pace rate required. This facility is available even if the Dual Pace option has not been selected. The following screen shows an example of a dual pace rate test.



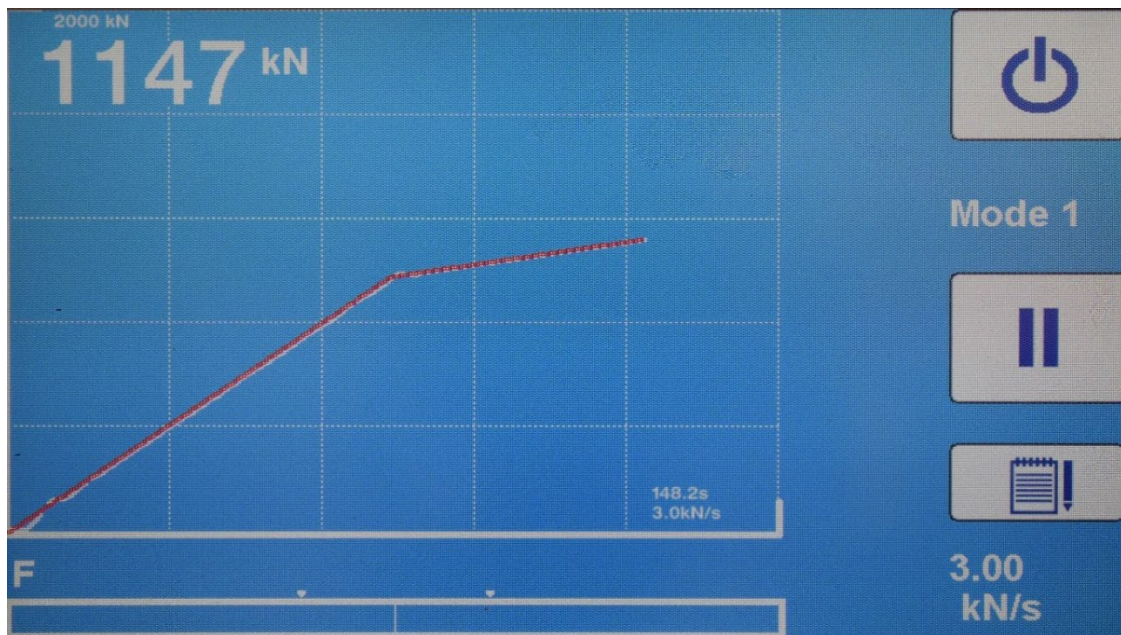

**Note: The ADR Touch Control PRO will only accept a range of pace rates. This range depends on the load frame being used and any maximum pace rate set in the service parameters. See Appendix 2 for the pace rate limits.**

#### 4.6.2.1 Dimensions

If the sample dimensions required are not the standard ones chosen when selecting the sample type and size, they can be altered here. Select the required entry field and use the numeric keypad to enter the new dimensions. These new dimensions are held by the ADR Touch Control PRO until a new sample type is selected. The sample dimensions are used by the ADR Touch Control PRO when stress is calculated.

**Note: The number and descriptions of the dimensions fields will depend on the sample type selected.**

If the test type is set to Flexural, a **Separation** dimension is shown when the appropriate sample type is selected. This dimension is the roller separation, and is used in the stress calculation for beams. There are two types of flexural roller bearing setups, a centre point loading and a 2-point loading (also known as Third Point Loading). This can be altered if required. See Appendix 1 for details of its use.

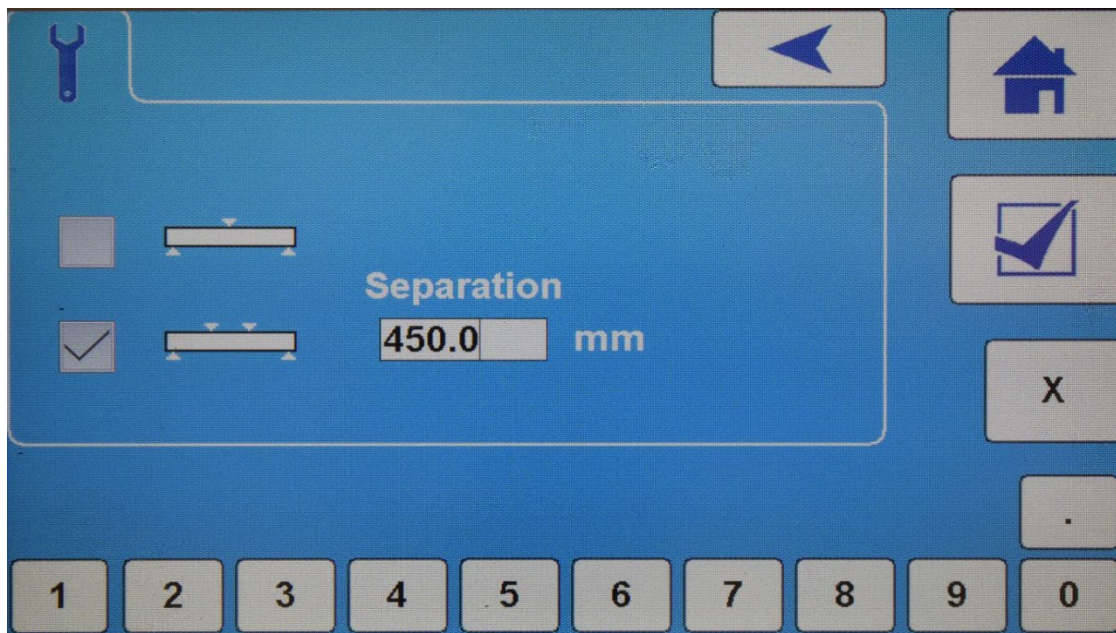

#### 4.6.3 Starting Pacing

Once the ADR Touch Control PRO has been set up it is ready to test a sample. Place the sample in the load frame, leaving 5 to 10 mm of clearance between the sample and the top platen. When ready press the **Enter** key. The screen display will now switch to the large character test screen and be of the form:

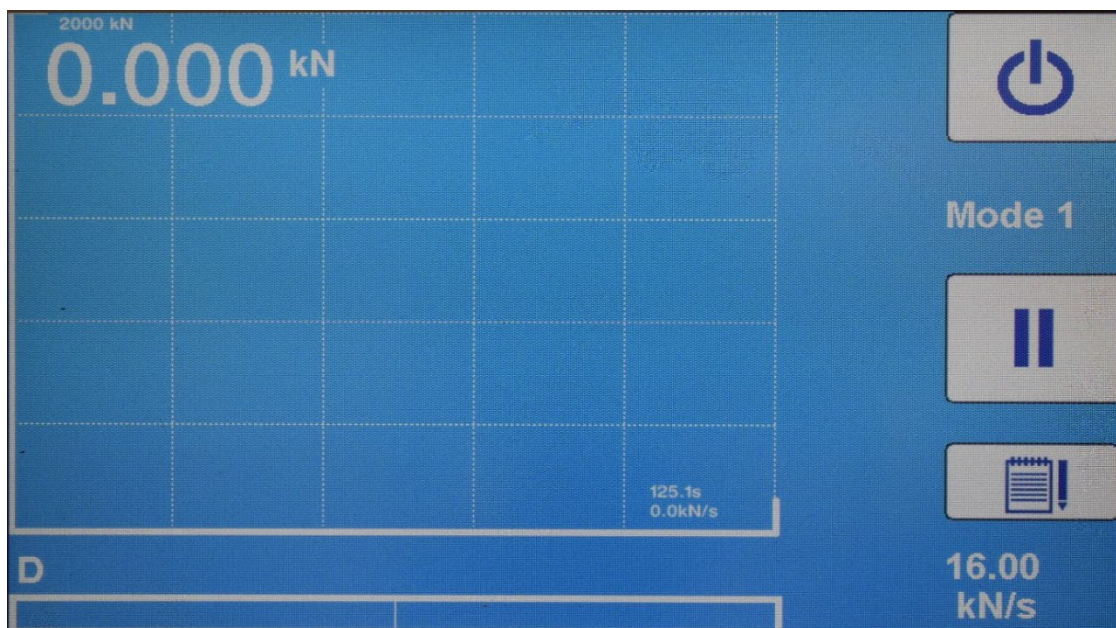

At this point the ADR Touch Control PRO's main pump will turn on and the ram will start to rise. On 2000 kN and 3000 kN models, the Rapid Approach Pump will engage to quickly close the daylight gap between the sample and the upper platen. The Rapid Approach Pump will switch off when the load on the sample is greater than the Close Threshold value. The load on the sample is displayed in the upper left corner of the screen and the pace rate for the test is displayed in the lower right corner.

The sampling rate for the update of the load value and the load vs time graph is fixed at 4 Hz.

The lowest line on the screen is the pace rate error bar display, which shows the difference between the required rate and the rate achieved by the ADR Touch Control PRO. When the load reaches 10% of the maximum frame capacity, two markers are displayed on the pace error bar showing the value of the pace bar width.

During the course of the test, a series of letters are displayed in the bottom left corner of the screen signifying the part of the test cycle that is currently running.

P – Moving to Pump Base

T – Taring

D – Daylight Closing

V – Engaging Pace Control

E – Controlling Under Failure Threshold

F – Controlling To Failure

**Note: In Board control mode, the letter 'V' is replaced by the letter 'B'.**

#### 4.6.4 Pacing Control

The ADR Touch Control PRO has two ways of controlling pace, Automatic and Board (the correct one of these must have been selected when setting the options in the **Close Threshold and Control** screen). The selected option comes into effect once the ADR Touch Control PRO has closed the gap between the sample and the upper platen, and has detected an increase in load on the sample which exceeds the Close Threshold.

During the course of the test cycle the ADR Touch Control PRO displays a graph of Load vs Time. This graph shows a live readout of the loading rate delivered to the sample (the WHITE trace) and also a line of perfect linear loading (the RED trace). The operator is able to see at a glance if the pacing has been compliant throughout the test cycle.

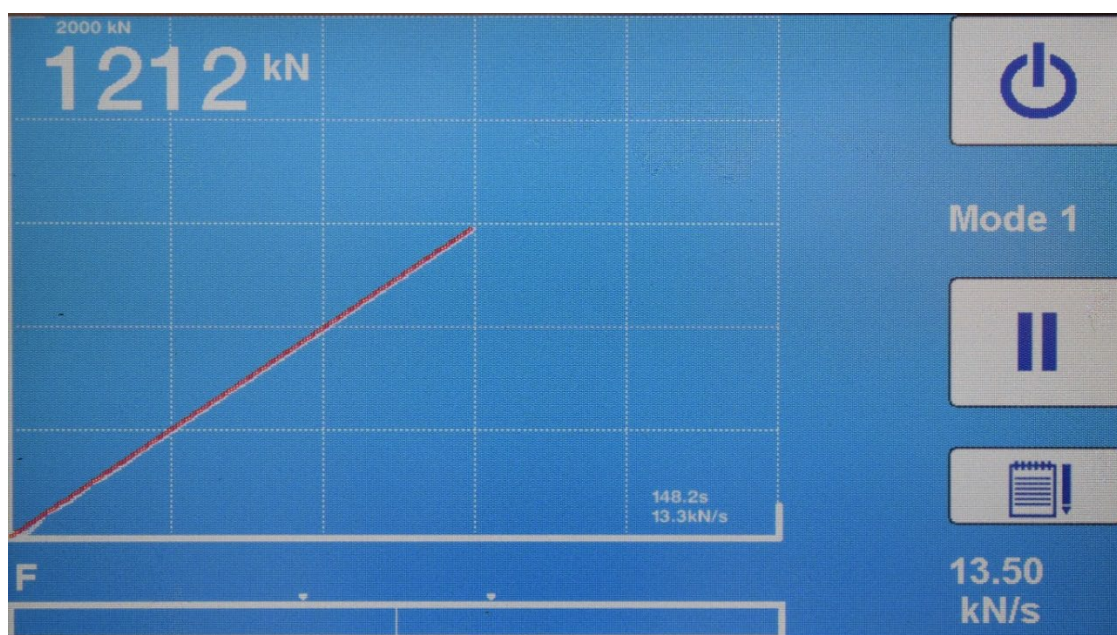

#### 4.6.4.1 Automatic

Once the ADR Touch Control PRO detects that the sample is being loaded, it turns on the pace control system. At the start of the loading cycle, the pace error bar will show an error but this will soon stabilise as the automatic pacer takes over.

#### 4.6.4.2 Board

Once the ADR Touch Control PRO detects a load on the sample, it applies load as fast as possible to compress the board on either side of the sample. This continues until the average pace rate measured is 90% of the set rate. The pace control system is then turned on.

#### 4.6.5 Pace Error Bar Display

When the ADR Touch Control PRO is loading the sample, the error display takes the form of a bar running from the central line to either the left or right. The length and direction of the bar is proportional to the pace error.

#### 4.6.6 Altering the Pace Rate whilst the Test is Running

The pace rate (or pace rates and transition load if dual rates have been selected) can be changed at any time while the sample is being loaded. Press the **Edit** key and enter the new values. The new values take effect when the **Enter** key is pressed.

**Note: The pace bar display will show an error until the ADR Touch Control PRO is pacing at the new rate and the trend data graph will reset. This will not affect the logged data for the test.**

#### 4.6.7 Pausing the Test

If the ADR Touch Control PRO is controlling the pace rate (in Automatic or Board pace control modes), the test can be paused at any time by pressing the **Pause** key and the ADR Touch Control PRO will hold the load constant. Press the **Run** key to resume loading at the set pace rate.

#### 4.6.8 Overload Conditions

If the load reaches the frame limit before the sample fails, the ADR Touch Control PRO will display the message "OVERLOAD". The load will continue to increase until it gets to 10% above the maximum frame rating and then the load will be released and the machine will shut down. At this point, a warning icon and an error message "Stopped Due To Overload" will be displayed. Press the **Home** icon to clear the alarm and return to the **Home Screen**.

#### NOTICE

The ADR Touch Control PRO is fitted with a mechanical safety device, a Pressure Relief Valve, which ensures that, in the case of a catastrophic failure, the pressure cannot exceed the design limits and cause injury or damage. The load frame has a significant overload safety factor designed in so that this condition will not damage the machine nor cause injury to the operator. This may begin to operate before the 10% limit has been achieved.

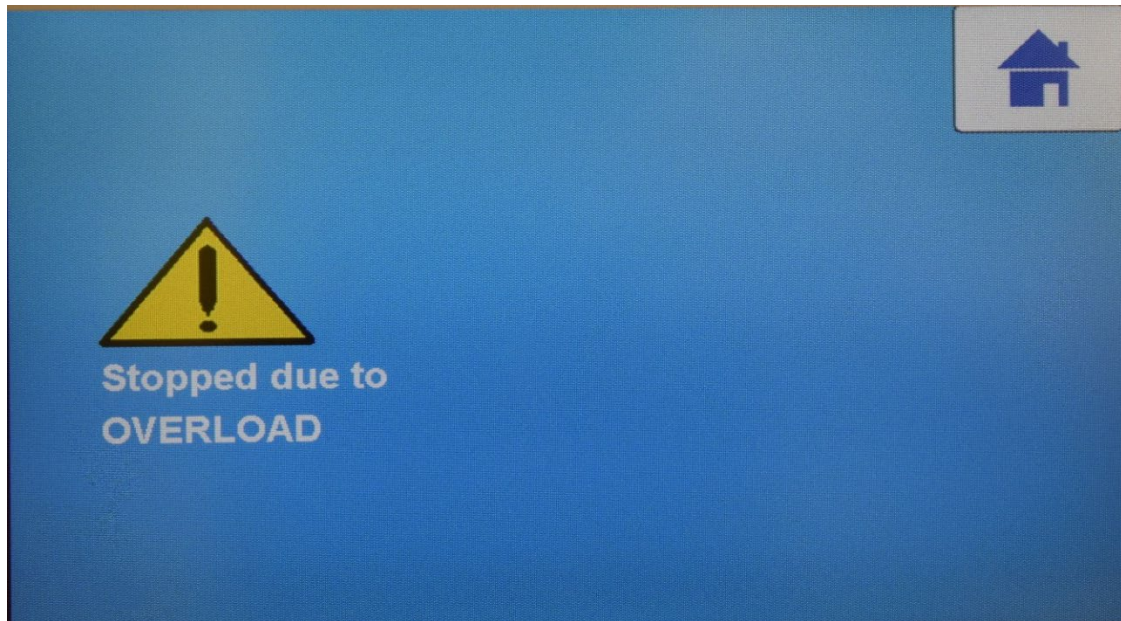

#### 4.6.9 Ram Run-out Conditions

If a test is started and no sample is present in the frame, the ram will continue to rise until the ram runout switch is tripped. This will cause the pump to stop and the dump valve to operate. The ram will then return to its original start position and a warning message will be displayed on the screen. The ram runout switch is connected in series with the Safety Gate Interlock (see below). If either of these conditions is active an Interlock Active message will be displayed.

#### 4.6.10 Safety Gate Interlock

The load frame is fitted with an Interlock switch attached to the safety gate. The safety gate **must** be closed before starting a test. If the safety gate is opened during a test, the interlock switch will cut the power to the motor and dump the load. A warning message will be displayed on the screen. To clear the warning message, press the **Home** icon.

A test cannot be started until the safety gate is closed. A warning message "Interlock Active" is displayed on the Initial screen when either the safety gate is open or the ram runout switch is active.

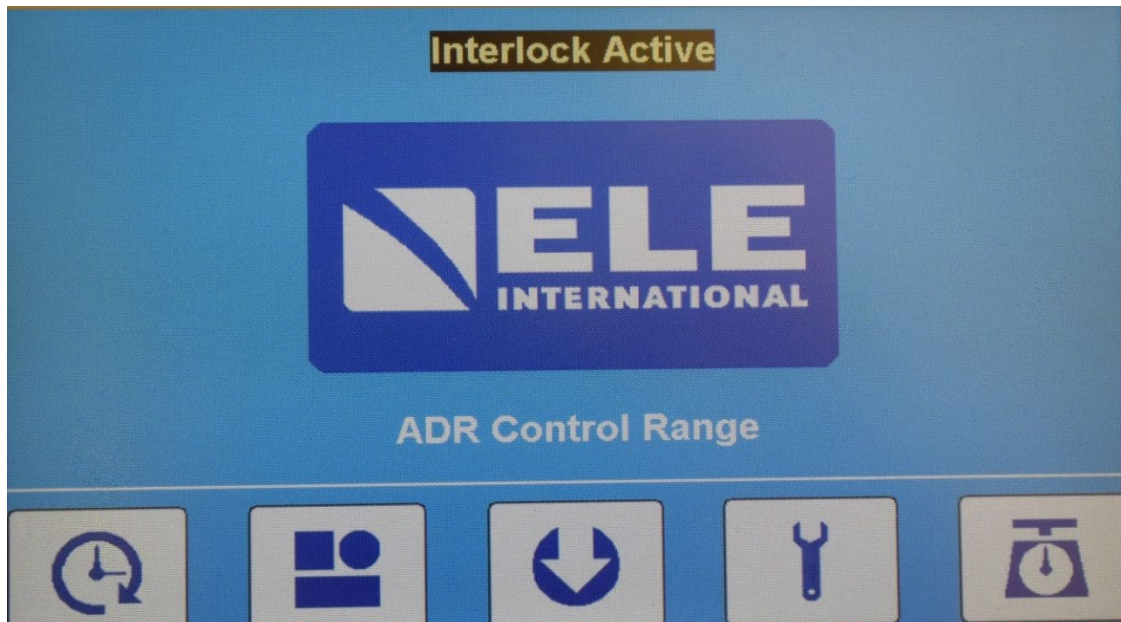

#### 4.6.11 Methods of Stopping a Test

The ADR Touch Control PRO will recognise several methods of a test cycle ending. The way in which the test cycle ends is reported in the test results file under the Title - 'Stopped Due To'.

If a test stops due to a sample failure then this will be reported as - **Sample Failure**.

If a test is stopped manually this will be reported as - **User**.

The following stop reasons are also reported on the screen but no results file is generated.

If a test is stopped by operation of the Emergency Stop button this will be reported as - **E-Stop Is Active**.

If a test is stopped due to the safety gate interlock switch or ram runout switch this will be reported as - **Protection Input Fault**.

If a test is stopped due to the load exceeding the frame capacity this will be reported as - **Overload**.

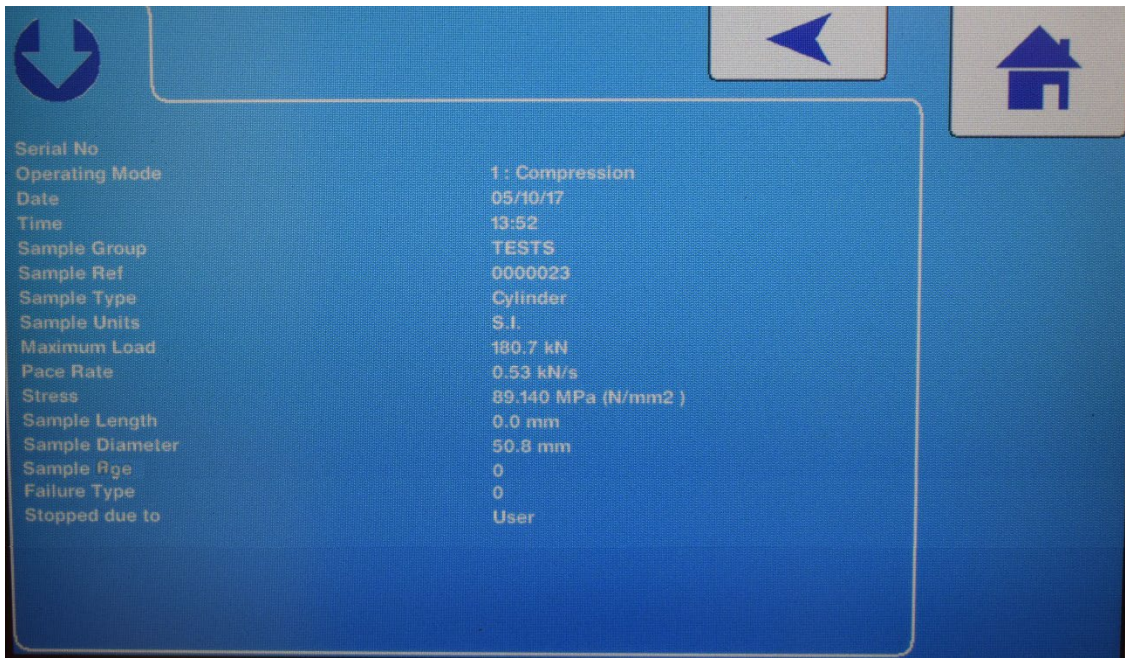

#### 4.6.12 Stopping the Test Manually

The test can be stopped at any time in the cycle by pressing the **Test Stop** icon . The ADR Touch Control PRO will report this as a test stopped due to - **User**.

#### 4.6.13 Sample Failure

While the sample is being loaded, the ADR Touch Control PRO is continually comparing the current load on the sample with the peak load seen by the sample. When the current load is below the peak load by the percentage set in the Failure Level field (the default setting is 15%), the machine senses this as a failure, switches off the pump and dumps the load. The screen will then switch to show the sample failure details and will be of the form:

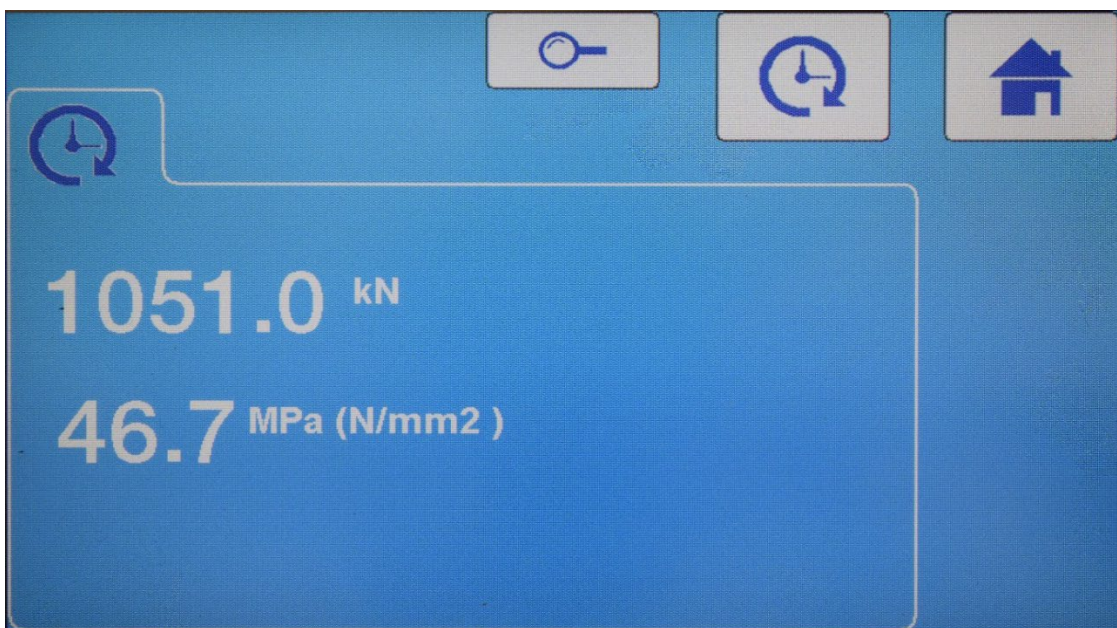

**Note: The stress value is not calculated for all sample types when the test standard requires a manual calculation of the sample cross sectional area. See Appendix 1 for the stress calculations performed by the ADR Touch Control PRO.**

Pressing the **Zoom** icon will display the test results in report format:

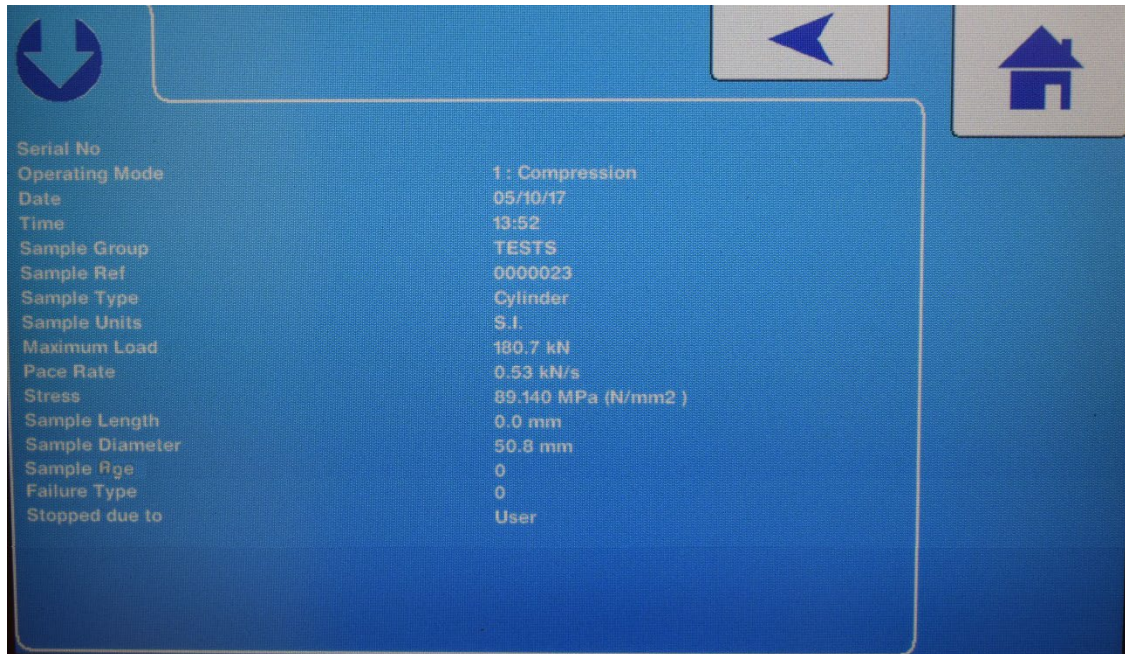

Serial No	
Operating Mode	1 : Compression
Date	05/10/17
Time	13:52
Sample Group	TESTS
Sample Ref	0000023
Sample Type	Cylinder
Sample Units	S.I.
Maximum Load	180.7 kN
Pace Rate	0.53 kN/s
Stress	89.140 MPa (N/mm <sup>2</sup> )
Sample Length	0.0 mm
Sample Diameter	50.8 mm
Sample Rge	0
Failure Type	0
Stopped due to	User

To prepare the ADR Touch Control PRO for the next sample, press the **Back** key to return to the results screen and then the **Test Start** icon. At this point, if the options have been configured, the ADR Touch Control PRO will print out the test results and record the results in the memory.



#### 4.6.14 Printing the Test Results

The test results will be automatically printed following the End of Test if the automatic printing option has been selected and the optional serial printer has been connected. Otherwise the **Sample Failure Details** may be recalled for printing by selecting the

**Saved Data** icon  from the Initial screen. The screen will then switch to show the Results data log and will be of the form:

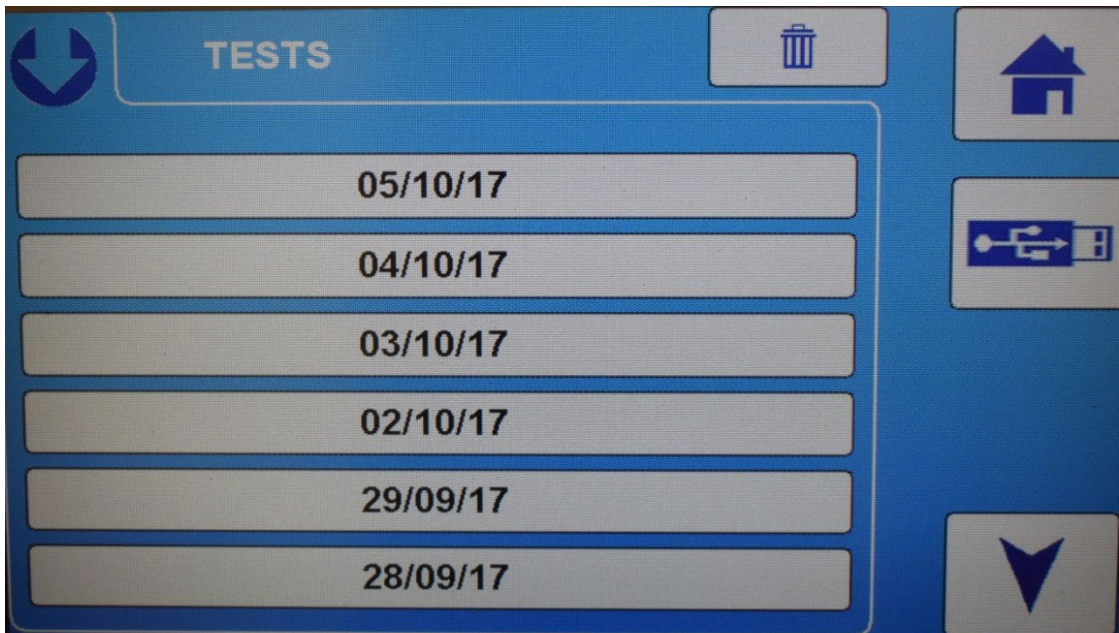

Use the **Arrow** icons to scroll through the records and select the desired date folder. When the folder is selected, a file name with the Sample Reference and Time of the test will be displayed.



The newest entry is shown at the top of the screen.

By selecting the desired record number, the relevant Results data can then be viewed. This record can then be printed by pressing the **Print** icon on the screen. (See Section 4.10 for the printer configuration).

**Note: If no optional printer is fitted then the Print icon will not be displayed.**

#### 4.7 ACV and TFV Tests

The ADR Touch Control PRO does not look for a sample failure when testing ACV or TFV sample types.

The way the ADR Touch Control PRO controls the loading of the sample is different when the sample has been chosen for an Aggregate Crushing or Ten Percent Fines Value test. For the ACV and TFV tests, provided that the automatic form of pace control has been selected, the machine will control the loading of the sample at the entered pace rate until the load specified in the **Failure Threshold** parameter is reached, at which point the load is dumped, and the peak load displayed.

**Note: For both ACV and TFV sample types, the ADR Touch Control PRO automatically sets default values of 0.65 kN/sec for the pace rate, and 400 kN as the termination point, so that the compression cycle lasts 10 minutes and ceases when a load of 400 kN is reached.**

#### 4.8 Recorded Test Results

The ADR Touch Control PRO has an internal micro-SD card and can store over a hundred thousand individual test results. The results can be viewed or printed by selecting the **Saved Data** icon on the Initial Screen, see Section 4.6.14. The recorded test log can be cleared by selecting the **Saved Data** icon and pressing the **Delete** icon. This will clear **all** of the saved results in the active test folder.

**Note: If more than one test folder has been created then this process will need to be repeated for each folder.**

Results data can also be cleared using the supplied ELE Logger software. See Section 5 on the **ELE Logger** for more details.

##### 4.8.1 Downloading Test Data

Test result data from the ADR Touch Control PRO can be downloaded in two ways.

The machine is supplied with the **ELE Logger** software package which is configured to run on a Windows based PC or laptop. The external PC can be connected to the digital head via the Ethernet port directly or through a Local Area Network (Router).

In order to connect via Ethernet, an IP Address for the ADR Touch Control PRO must be set up or be assigned to it automatically. The IP Address facility can be found in the Comms Port Settings menu.

The stored test data can also be accessed by connecting the digital head to a Windows PC or laptop via the supplied USB cable. The cable should be fitted to the Type B USB connection on the digital head and then to a spare Type A USB port on a suitable PC. To complete the connection, press the **Saved Data** icon then select the **USB** icon. When a connection has been made, a screen displaying just the USB icon and the Home icon is shown on the digital head.

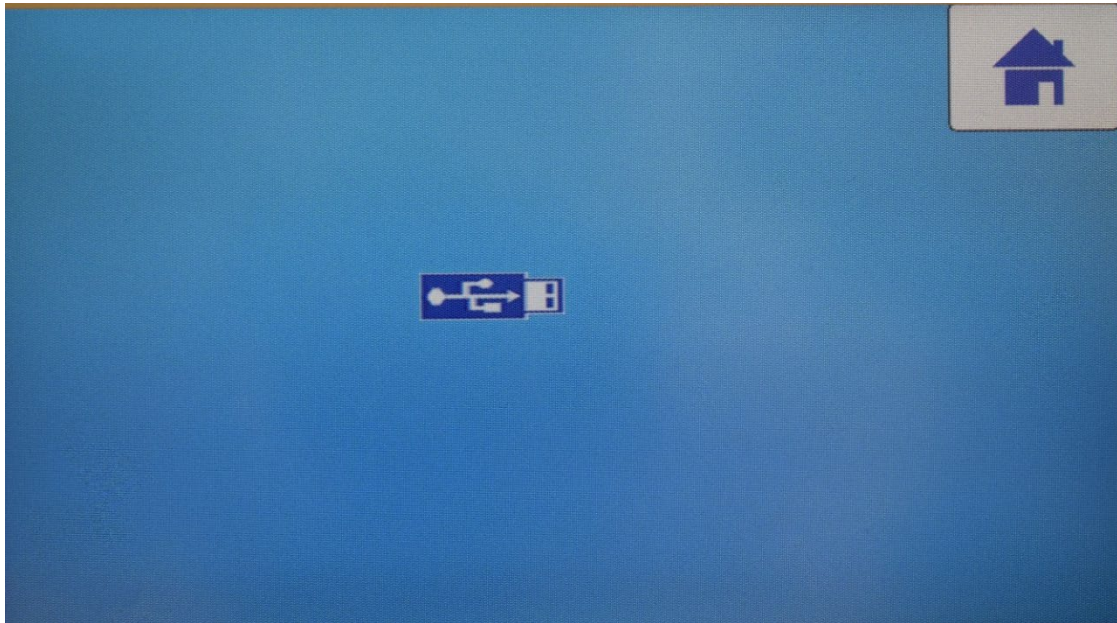

The ADR Touch Control PRO will then become visible on the connected PC as a removable memory device. All created test folders will be visible and the data files from each can be copied to another location. The contents of the original files can then be deleted. Test results files are output as .csv file type which can be opened in Microsoft Excel for further processing and analysis.

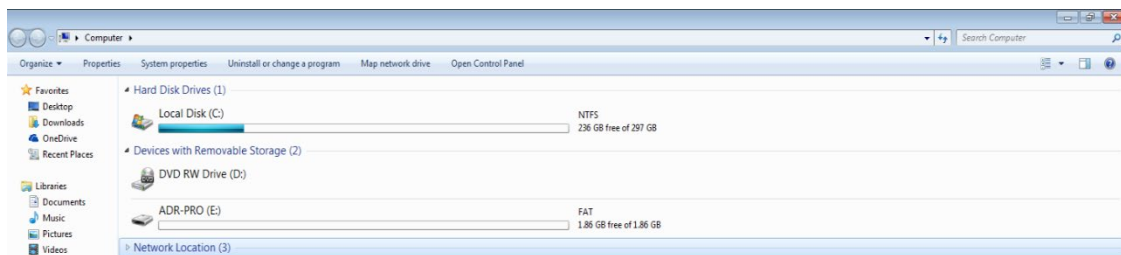

**Note: All test data, when downloaded from the ADR Touch Control PRO, is output in S.I. units, regardless of the units that the test has been run in. However, a Units parameter within the data will indicate what units were selected when making the test. This can be used in an Excel Macro to convert the data from S.I. to the original units (if different).**

#### 4.9 Verifying the Measurements

This option is available from the **Settings** menu and is used to check the ADR Touch Control PRO's calibration. Refer to the ADR Touch Control PRO Service Manual for details.

#### 4.10 Configuring the Printer

Connect the printer to the serial port on the back of the display head (see Section 4.15). When the printer is switched on the Print icon will show in the Saved Data screen (see Section 4.6.14).

#### 4.11 Calibrating and Testing the ADR Touch Control Pro

The ADR Touch Control PRO's Calibration and Test facilities are accessed from the **Calibration** options screen. Entry is password protected to prevent unauthorised access. This area should only be accessed by qualified users under the guidance of ELE International.

**Note: Irrevocable damage to the information stored in the memory of the ADR Touch Control PRO can be done in this menu which could result in the machine becoming unusable.**

#### 4.12 Data Retention and Backup

The ADR Touch Control PRO's test data and system configuration is preserved when the power is removed.

##### 4.12.1 Real-time Clock

A real-time clock is powered by a small LiMn Dioxide battery when no external power is present. This will maintain the internal clock for up to 5 years even when there is no system power present and for much longer when the unit is normally powered up.

##### 4.12.2 Configuration Data

All calibration and configuration data is held in non-volatile memory, and cannot be lost under normal conditions. All changes to the configuration are stored as they are made.

#### 4.13 Error Conditions and Messages

The ADR Touch Control PRO continually checks critical performance parameters and displays an error message if a malfunction is detected. If an error is detected, a dialogue box with the error code will be displayed. If the error has resulted in the machine being shut down and unable to operate further, this error must be fixed and cleared before the operation can continue. See Appendix 8 for a list of error codes and their meanings.

If the error persists or further assistance is required, contact the ELE service engineer or consult the Service Manual.

#### 4.14 Communications Interface (RS232)

The ADR Touch Control PRO's RS232 serial port is used to output data to a serial printer or can be used to communicate with a LIMS system.

**Note: The RS232 port uses two pins configured for RTS/CTS which are used to detect the presence of a serial printer. To use the RS232 output for communication with a LIMS system, the RTS/CTS pins (pins 7 and 8) must be linked out.**

##### 4.14.1 Baud Rate

The Baud Rate is set at 9600 as a default but can be changed to 115200.

##### 4.14.2 Format

The word format is 8 bits, no parity and 1 stop bit.

##### 4.14.3 Terminator

The Terminator setting defines what the ADR Touch Control PRO adds at the end of a line. This is Carriage Return followed by a Line Feed (CR/LF).

4.15 Rear Panel Connections

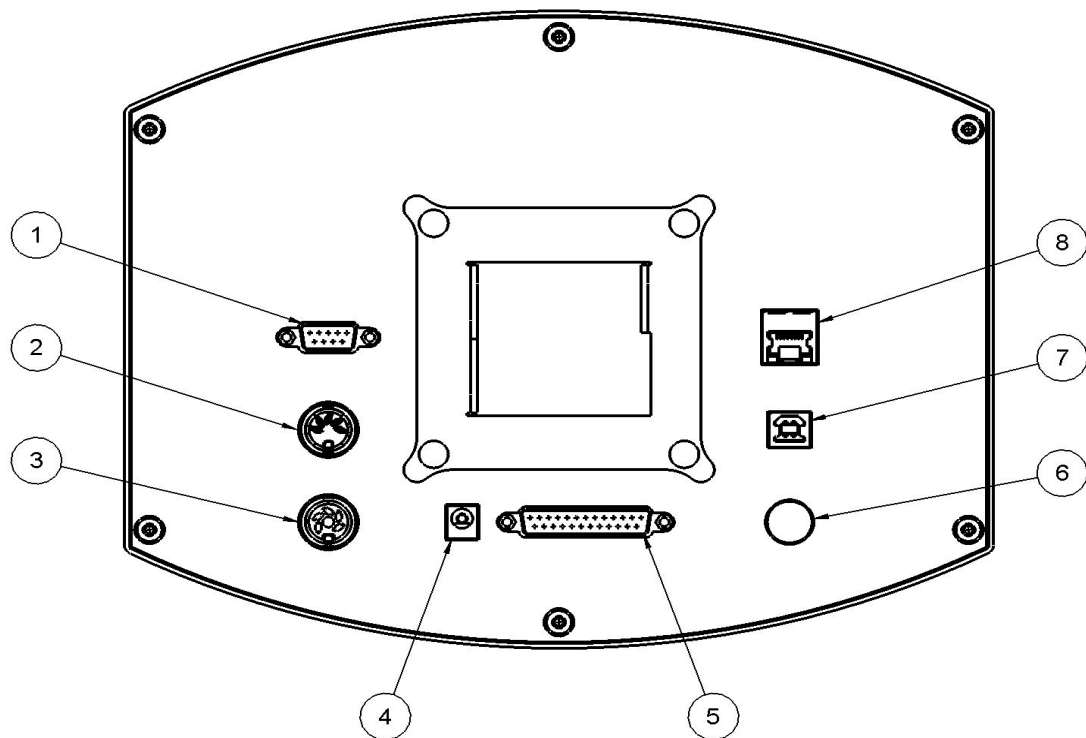
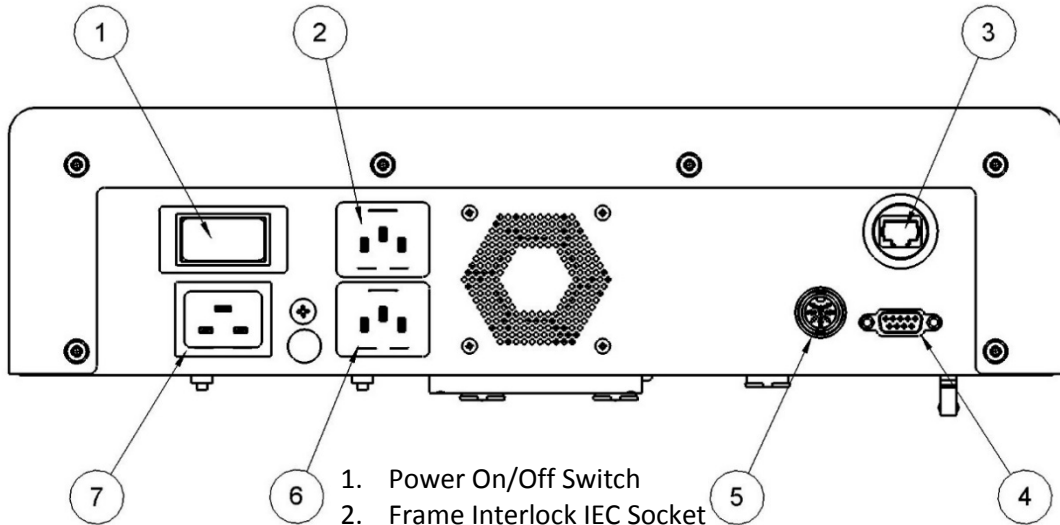

1. Power On/Off Switch
  2. Frame Interlock IEC Socket
  3. Ethernet Port
  4. Manual Override Socket
  5. Not Currently Used
  6. Frame Interlock IEC Socket
  7. Power Cable Connection
- 
1. Serial Port/Printer Connection
  2. Transducer 2 (Optional)
  3. Transducer 1
  4. Power In
  5. Communication Cable Connection
  6. Manual controller input (ADR Touch PRO mode)
  7. USB Port
  8. Ethernet Port

#### 4.15.1 AC Input Power

The AC power input consists of an IEC C19/C20 pair and separate switch. The 220-240V models use a 5 Amp Dual Pole Illuminated Switch Circuit Breaker. The 110V model using a step up transformer will be similarly fused or use a 10A breaker if supplied direct from 110V.

#### 4.15.2 Door Guard/Ram Travel Limit Switch Inputs

The ADR Touch Control PRO has two Door Guard/Ram Travel Limit IEC sockets.

#### NOTICE

The Door Guard/Ram travel limit connections are for connection to the adjacent compression frames. These outputs are not for connection to other equipment. The output is at 24V DC with a 250mA resettable fuse.

Ensure that the connectors from the frames are plugged in. Where only one frame is fitted, a dummy plug must be fitted in the unused socket.

#### 4.15.3 Manual Control

This connection is via a standard 9 way 'D' plug and is for service use only. It can be used with an ELE Manual Override 1676B0070. See Service Manual for information.

#### 4.15.4 Serial Port

The ADR Touch Control PRO has an RS232 serial port for connecting the optional serial printer. The output is via a standard 9 way 'D' plug.

Pin	Signal
1	-
2	Received Data (RxD)
3	Transmitted Data (TxD)
4	-
5	Signal Ground
6	-
7	Ready To Send - RTS
8	Clear To Send - CTS
9	-

#### 4.15.5 USB Port

The USB port is used for firmware updates to the system's software (see below), to take copies of configuration data and to export data to a PC. It is also a non-preferred method of taking a copy of the test results data.

#### 4.15.6 Updating the Firmware

In certain circumstances, it may be necessary to update the firmware stored in the ADR Touch Control PRO.

Connect the ADR Touch Control PRO to a Windows PC or laptop via the USB port and select the **USB** icon in the **Saved Data** menu. The ADR Touch Control PRO will now be visible to the external PC as a removable memory device. The root directory of the ADR Touch Control PRO will contain a file called Image.BIN - this is the firmware file.

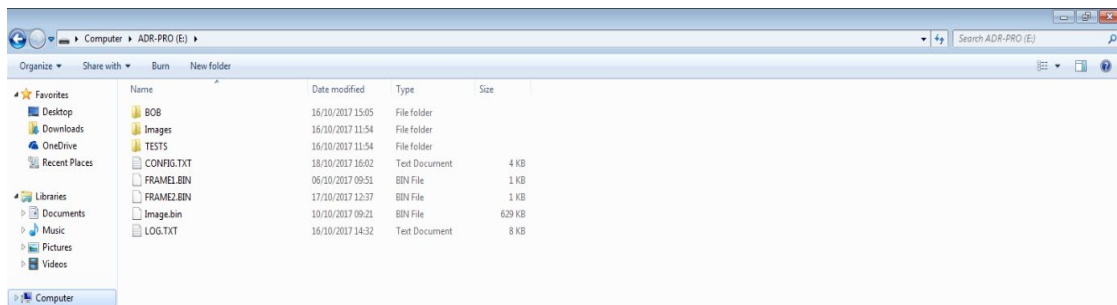

In order to update the firmware file, take a copy of the existing file and save it to another location. Copy and paste the updated firmware file into the root directory of the ADR Touch Control PRO, selecting “Copy and Replace” when prompted.

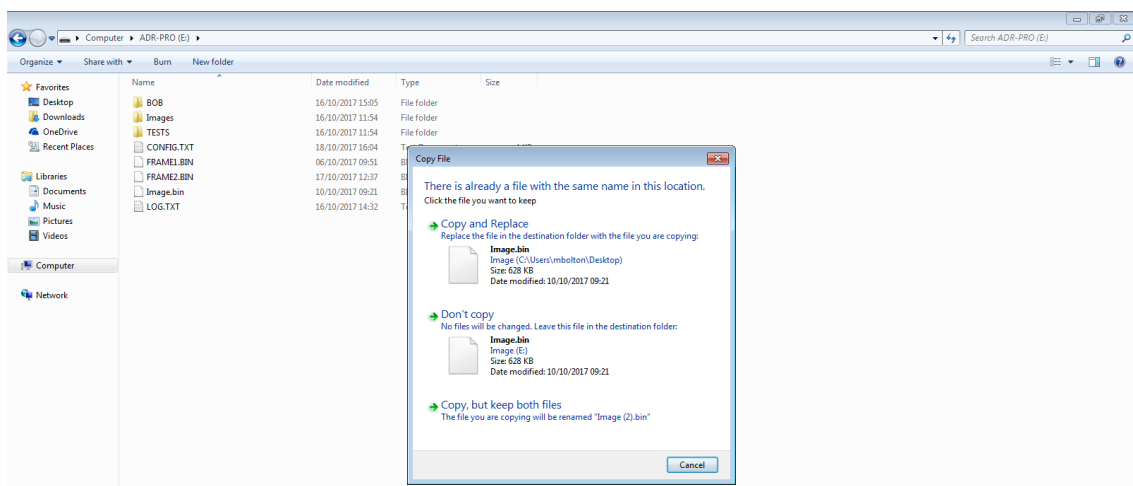

After updating the firmware, safely remove the device from the **PC using the ‘Eject’ function and remove the USB cable**. Switch the ADR Touch Control PRO OFF and back ON. Confirm the new update is programmed when the unit powers up, “Programming new image.....” is displayed, followed by “success”. To check the version of firmware loaded, look in the Display Version Menu section.

## 5 ELE Logger

### 5.1 System Requirements

The software supplied with the ADR Touch Control PRO (ADR TCP), used for monitoring and reviewing tests, is known as the ELE Logger. The Logger software runs on an external, Windows-based PC or laptop and a connection is made from the ADR head to the external PC via the Ethernet ports, either directly (P2P) or through a Local Area Network (Router). There are three methods for connecting the ADR TCP to the PC application via the Ethernet connection. A static IP address is the preferred option (see section 5.3) with a P2P connection (section 5.4) being second best. The use of an automatic IP address (DHCP) from a router is viable, but since the assigned IP address may change if the ADR TCP is power cycled, it is not preferred.

The system requirements for the PC or laptop to run the ELE Logger application are:-  
Windows 7/Windows 10.

2GB RAM.

## 5.2 Installing the ELE Logger Software

Insert the memory stick supplied with the machine into a spare USB port on the host PC. Double-click to run the Runme.bat file to copy the files to the local drive.

The logger application can now be run by double-clicking the **ELE Logger** shortcut.

To speed up access to the logger, copy the shortcut onto the desktop of the PC.

## 5.3 Direct Connection of the ADR TCP (Point-to-Point) to the ELE Logger

To connect an ADR TCP to the ELE Logger application on a PC with a P2P Ethernet connection, make the following actions as detailed in Appendix 9.

- 5.3.1 On the ADR TCP set up the connection for a manual IP Address. Select Tools>User Defined Settings>Comm Port Settings and confirm the flag in the **Auto IP Address** box is not ticked. In the Calibration Menu, select Diagnostics & Miscellaneous>Network Setup. Edit the IP Address to 192.168.0.101, Net Mask to 255.255.255.0 and Gateway to 192.168.0.1.

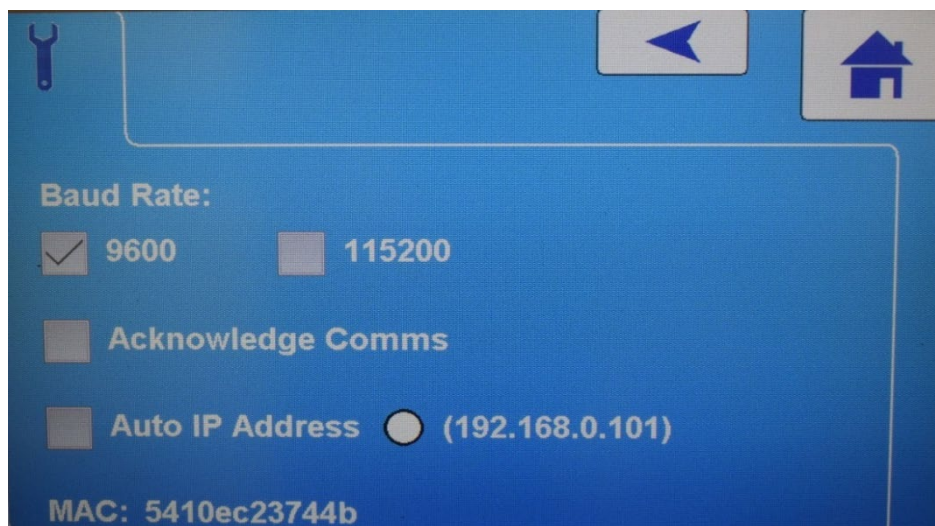



#### 5.4 Connecting the ADR TCP to ELE Logger via a Local Area Network with a static IP Address

To connect an ADR TCP to the ELE Logger application on a PC with an assigned static IP address, it will be necessary to obtain an assigned IP address from the relevant IT manager. Then set up the ADR TCP with the following actions.

5.4.1 On the ADR TCP set up the connection for a manual IP Address. Select Tools>User Defined Settings>Comm Port Settings and confirm the flag in the **Auto IP Address** box is not ticked. In the Calibration Menu, select Diagnostics & Miscellaneous>Network Setup. Edit the IP Address to that supplied by the IT manager. Edit the Net Mask to 255.255.255.0 and the Gateway as advised by the IT manager.

5.4.2 If multiple ADR TCPs are to be assigned on the network edit the ADR Number in the Calibration menu, Diagnostics & Miscellaneous>Network Setup. Confirm that there are no ADR TCP units with the same ADR Number.

#### 5.5 Connecting the ADR TCP to ELE Logger via a Local Area Network with an automatically assigned IP Address (DHCP)

To connect an ADR TCP to the ELE Logger application on a PC with an automatically assigned IP address, set up the ADR TCP with the following actions.

5.5.1 On the ADR TCP set up the connection for an automatic IP Address. Select Tools>User Defined Settings>Comm Port Settings and confirm the flag in the **Auto IP Address** box is ticked.

**Note: When the ADR TCP has been successfully established on the network the solid white symbol and IP address will become green.**

The assigned address will appear bracketed, for example (10.150.30.168).

If multiple ADR TCPs are to be assigned on the network edit the ADR Number in the Calibration menu, Diagnostics & Miscellaneous>Network Setup. Confirm that there are no ADR TCP units with the same ADR Number.

#### 5.6 Running the ELE Logger

Run the ELE Logger program on the PC and then make the connection to the required ADR Touch Control PRO.

Enter the IP address displayed on the ADR TCP Comms Port Settings menu, either the automatic address supplied by the router or the manually set up one in the IP Address field and then press Connect.

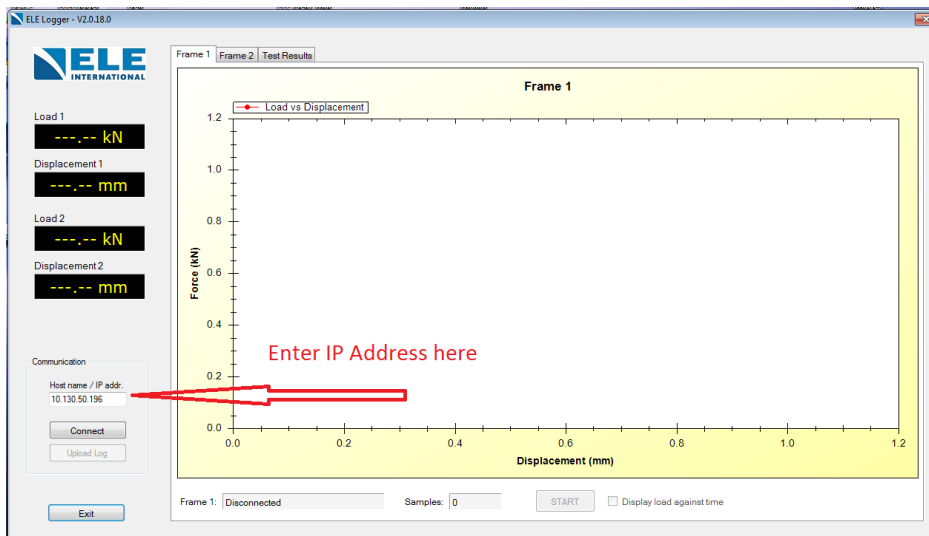

When communication has been established, the ELE Logger will show a Load vs Time screen with the Mode, Sample size and Pace Rate for the last recorded test as a title.

The ELE Logger will display real-time information during the test cycle when the Frame Data tab is selected. Where more than one frame is fitted, there will be Frame 1 and Frame 2 tabs. The load vs time graph is shown, as is the Pace Error Bar, allowing the test to be monitored remotely.

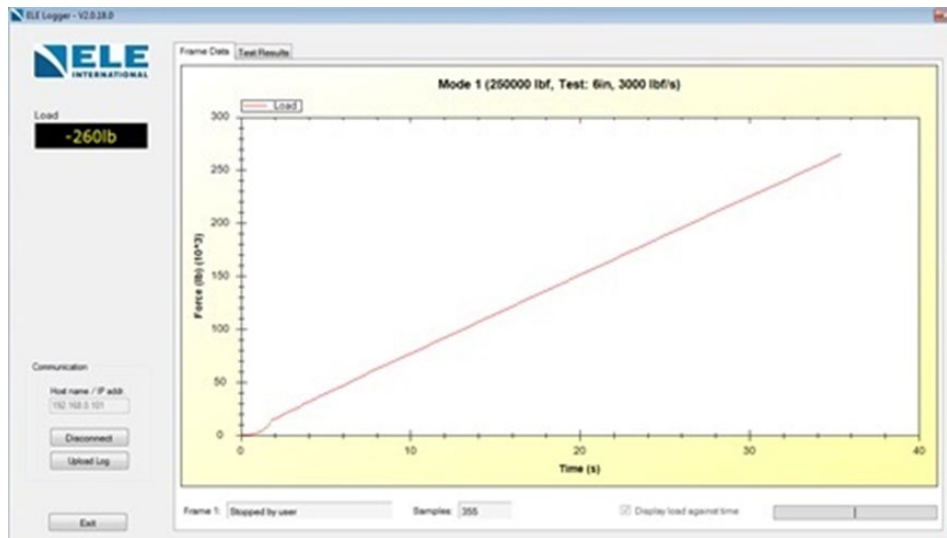

**Note: The graph title information is picked up from the last recorded test. This will change when a new sample is selected in the Test Setup screen. If the Pace Rate or Sample size is changed in the Test Setup screen, this change of data will not be shown in the graph title until the Test Setup screen is exited and entered again.**

Test results stored in the memory of the ADR Touch Control PRO can be automatically synchronised with the ELE Logger when a connection is made. Test results can be viewed by selecting the Test Results tab at the top of the screen and opening the desired folder until the results files are displayed. Test results are stored as .csv files and by selecting a file, the test results and sample data will be shown on the screen.

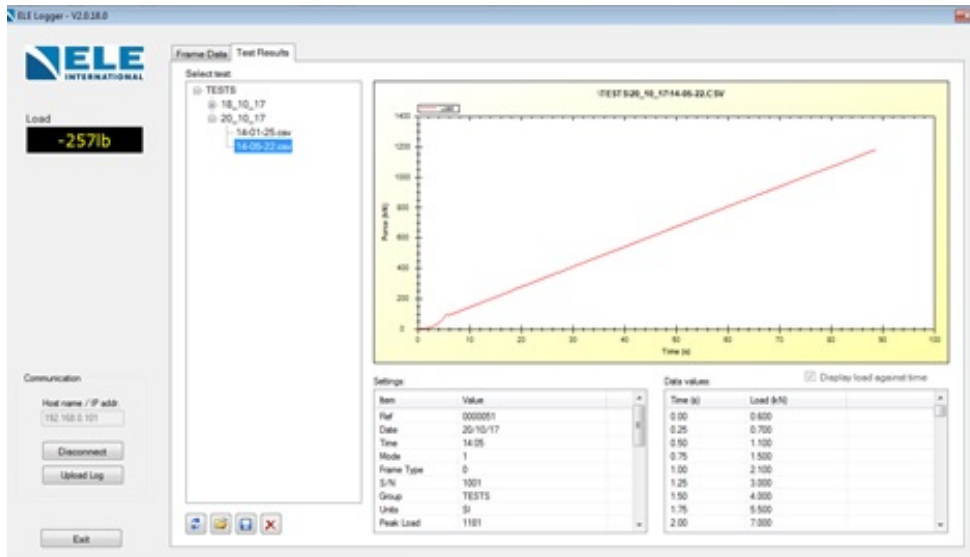

Test results stored in the memory of the ADR Touch Control PRO can be automatically synchronised with the PC. Follow the sequence given below to auto update test result files from ADR Touch Control PRO to PC.

Click on Test result tab and select top level folder to test results on PC.

Select or create a top-level folder to copy csv files.

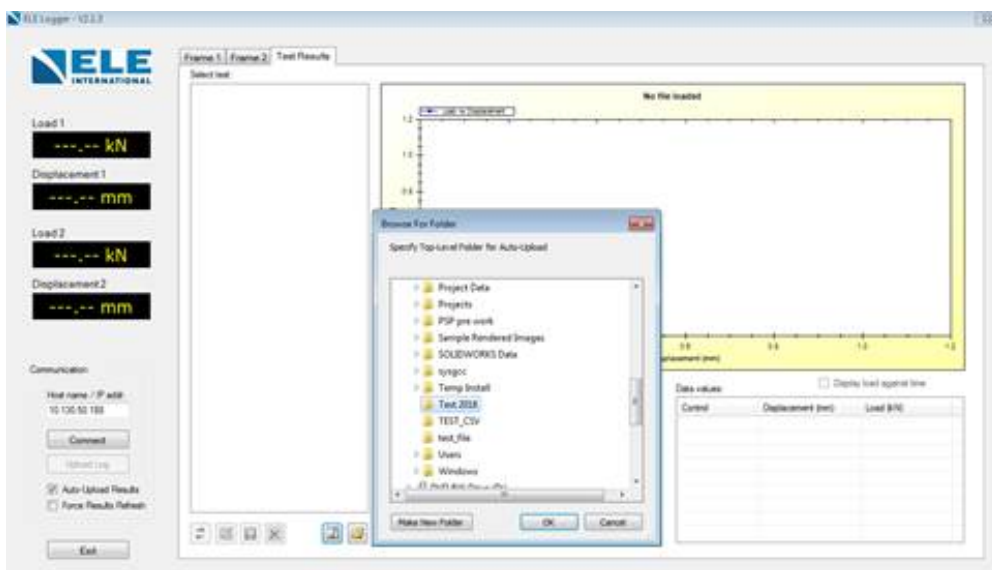

Tick Auto-upload Result button.

A message will appear when Connect button is pressed, Click Yes.

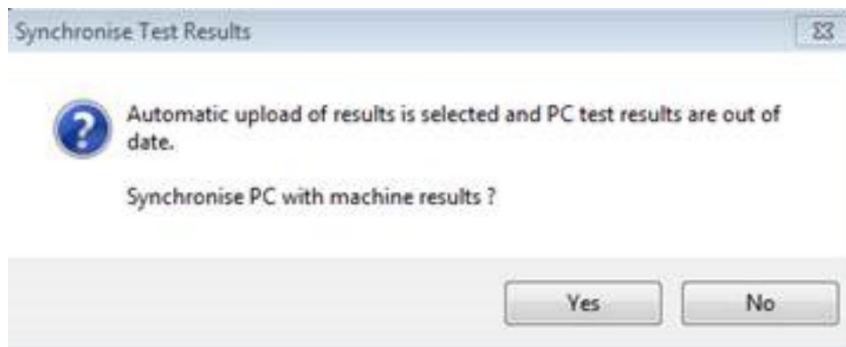

## 6 Maintenance

### 6.1 Daily

Always check that the platens are clean before commencing the test.

Remove the lower platen and distance pieces and clean thoroughly.

Brush away all concrete debris from the area around the hydraulic ram. In the case of 2000 kN and 3000 kN BS machines, raising the hydraulic ram will assist in the removal of this debris etc. from between the folds of the gaiter.

Check for signs of leaks in the hydraulic system.

### 6.2 Occasionally

Inspect gaiters for damage.

Check the oil level in the oil reservoir.

Inspect the platen for wear.

Check the oil in the reservoir for signs of contamination and replace if necessary.

Due to the design of the seal, a small amount of oil may 'seep' out of the ram. This is not a problem and should be wiped away as necessary.

### 6.3 Verification

It is normal National Standard requirements to request the verification of load measuring systems at least once each year or more frequently according to the work undertaken.

A verification should be undertaken after each occasion when any adjustment to the compression machine may have affected the load measuring system.

The verification of the load measuring system should be undertaken by qualified engineers using approved and certified equipment.

***Note: Always use a load spreader of approximately 150 mm diameter or more when calibrating machines to 3000 kN.***

## 7 Service and Spares

It is recommended that either the ELE Service Department or an authorised distributor be contacted for details of available spare parts or servicing requirements.

## 8 Rectangular Platen Handling Assemblies

### 8.1 Introduction

Unique platen handling systems enabling the upper platen to be quickly moved to provide access to and use of the ball seating. Particularly useful where cube testing to BS EN 12390-4 is specified, the facility does not affect the stability requirements of the ball seating.

All BS EN Compression Machines of 2000 kN and 3000 kN capacity can be supplied fitted with the above assemblies.

## 8.2 Specification

	2000 kN Machines	3000 kN Machines
Projection of rectangular platen assembly at rear of frame	465 mm	390 mm
Maximum vertical clearance (rectangular platens fitted)	245 mm	245 mm
Upper and lower rectangular platen dimension	445 x 250 x 75 mm	445 x 250 x 75 mm

For other details see specifications of load frame to which the Rectangular Platen Handling Assembly is fitted.

## 8.3 Installation

### 8.3.1 General

As supplied, the load frame will not have the rectangular platens fitted.

Before fitting the platens ensure that the load frame is level in both directions.

The upper platen is best fitted from the rear of the load frame and this should be taken into account when installing the frame.

### 8.3.2 Lower Platen

Remove the 4 blanking plugs from the ends of the lower platen and screw in the 4 lifting rods. (The lower platen is the one without the rollers.)

Open the load frame front gate.

Ensure the lower platen is the correct way up i.e. engraved lines at the top, then with the aid of an assistant and exercising extreme care, lift the platen onto the ram or distance pieces (see Figure 7.1) ensuring its correct location.

Remove the 4 lifting rods from the platen and replace the blanking plugs.

### 8.3.3 Upper Platen

Remove the 4 blanking plugs from the ends of the upper platen.

Then either screw in the 4 lifting rods or use the two "Dynamo" eyebolts. (The upper platen is fitted with rollers.)

If the eyebolts are installed then use appropriate lifting equipment and lower the upper platen onto the protruding rails so the rollers lie in the platen retainer indent. The flat face of the platen should face into the machine. The eye bolts are then removed, blanking plugs replaced and the platen can be swung up and over the rear end stops into position.

Using lifting rods, first remove the 2 rear stops (see Figure 7.1) from the handling assembly.

Using the lifting rods ensure the upper platen is the correct way up i.e. surface with recess at the top, then with the aid of an assistant and exercising extreme care, lift the platen and position it between the protruding rails (at the rear of the load frame) with the rollers resting on the top face of the rails (see Figure 7.1). Refit the 2 rear stops.

Remove the 4 lifting rods from the platen and replace the blanking plugs.

Ensure the platen rolls freely along the rails.

**Note: A latch is provided on 3000 kN machines (see Figures 7.1 and 7.2) to keep the platen at the rear of the load frame and clear of the ball seating during cube testing. On 2000 kN machines, a depression in the guide rails locates the transport rollers to keep the platen at the rear of the load frame.**

## 8.4 Operation

### 8.4.1 Block Testing

The maximum vertical clearance of 245 mm for block testing is achieved by locating the lower rectangular platen directly on the load frame ram (see Figure 7.2).

When testing blocks requiring less vertical clearance, the required distance pieces should be bolted to the ram and the platen located on the top distance piece (see Figure 7.3).

### 8.4.2 Cube Testing

100 mm and 150 mm cubes may be tested with the lower rectangular platen located directly on the load frame ram and the upper platen rolled to its rearmost position and retained either by the latch (3000 kN machines) or by seating the transport rollers into the depression in the guide rails.

Correct vertical clearance is obtained by fitting the adaptor into the central hole in the lower rectangular platen, then locating the required distance pieces onto the lower rectangular platen, topped by the Self-centring Lower Platen. For testing 100 mm cubes 1 x 80 mm and 1 x 100 mm distance pieces are required. For testing 150 mm cubes 1 x 80 mm and 1 x 50 mm distance pieces are required (see Figure 7.4).

## 8.5 Maintenance

Keep the rectangular platen handling assembly rails clean and ensure that the upper rectangular platen rolls freely along the rails.

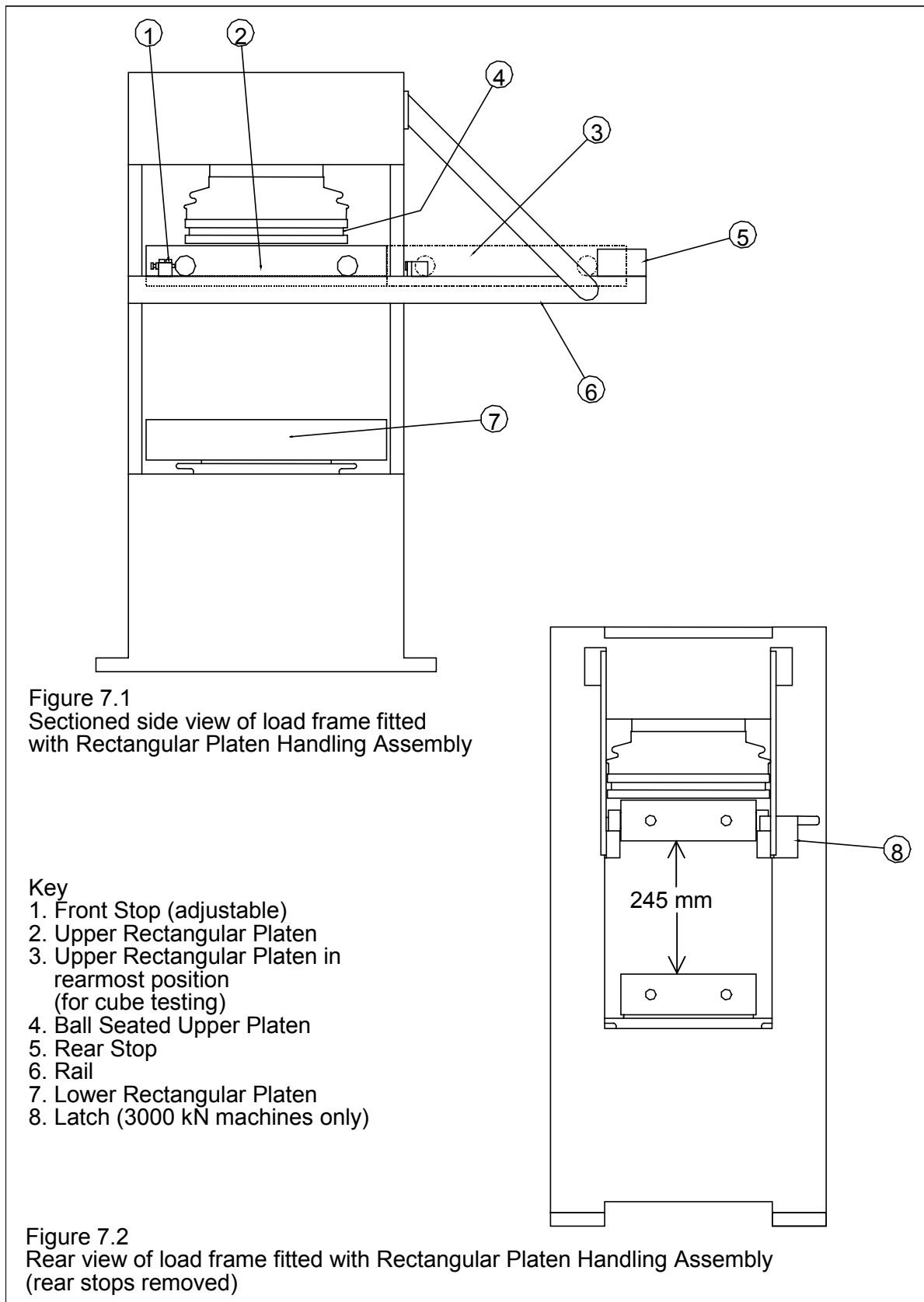



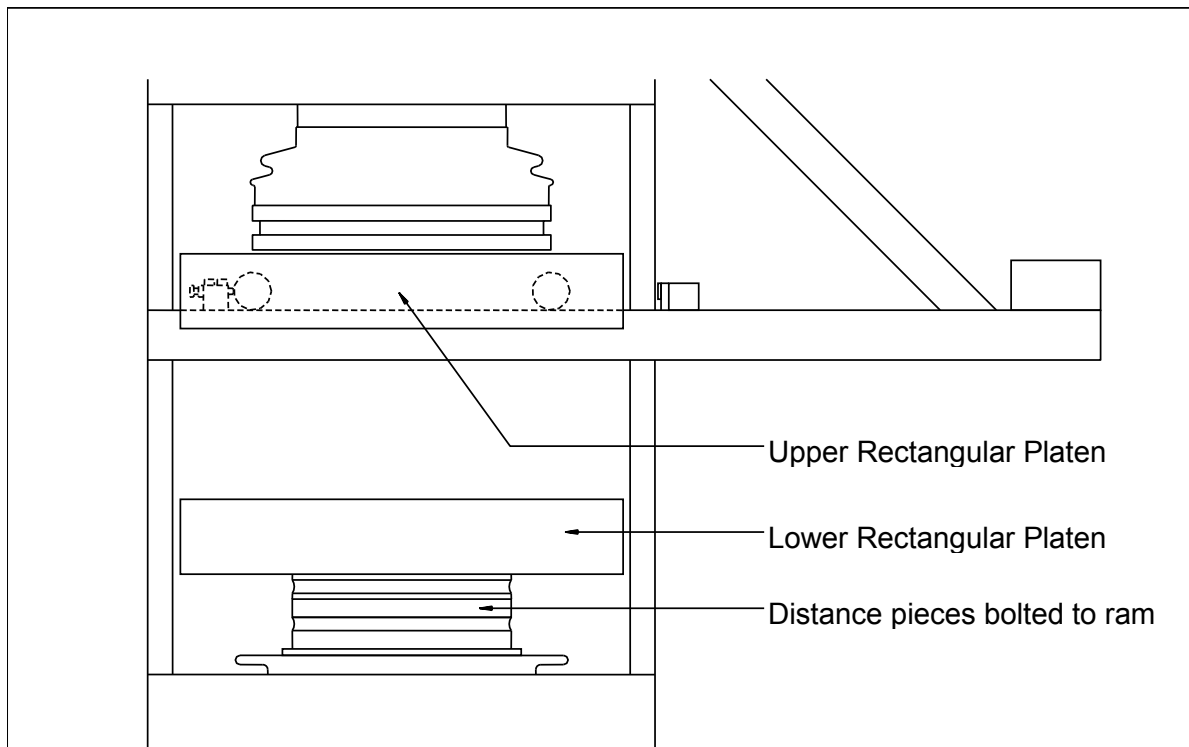

Figure 7.3. Set up for testing blocks requiring less than maximum vertical clearance

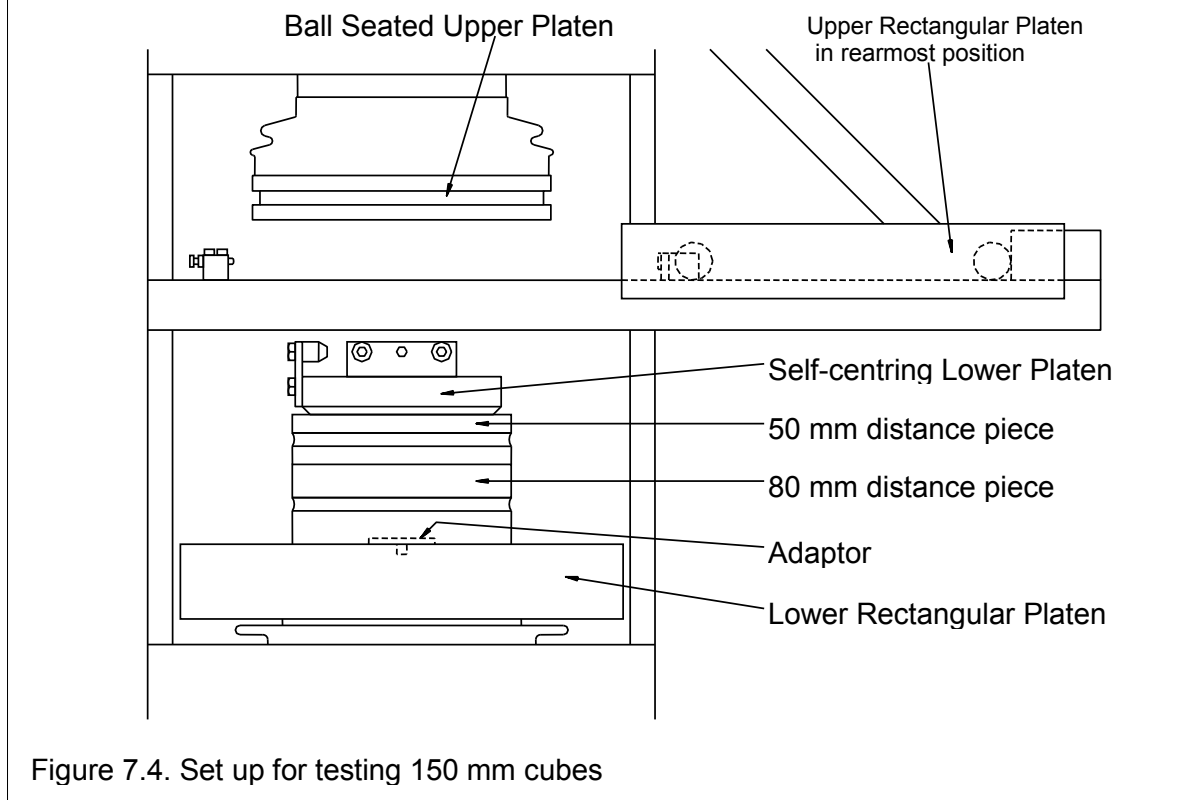

Figure 7.4. Set up for testing 150 mm cubes

## Appendix 1: Sample Types and Sizes

### Cubes

S.I. Units			
Size	Supporting Frames	Pace Rate	Standard
40 mm	250 kN	2.4 kN/s	BS EN 196-1
40 mm	1500, 2000 kN if dual sensor option enabled	2.4 kN/s	BS EN 196-1
50 mm	250, 1500, 2000 kN	1.8 kN/s	BS EN 12390-3
70.7 mm	250, 1500, 2000, 3000 kN	3.5 kN/s	BS EN 12390-3
100 mm	1500, 2000, 3000 kN	7.0 kN/s	BS EN 12390-3
150 mm	1500, 2000, 3000 kN	16.0 kN/s	BS EN 12390-3
200 mm	1500, 2000, 3000 kN	28.0 kN/s	BS EN 12390-3
Stress calculation $S$ (N/mm <sup>2</sup> ) = Peak Load (N) /D <sup>2</sup> (mm <sup>2</sup> )			

Metric Units			
Size	Supporting Frames	Pace Rate	Standard
4.0 cm	250 kN	240 kgf/s	BS EN 196-1
4.0 cm	1500, 2000 kN if dual sensor option enabled	240 kgf/s	BS EN 196-1
5.0 cm	250, 1500, 2000 kN	180 kgf/s	BS EN 12390-3
7.07 cm	250, 1500, 2000, 3000 kN	350 kgf/s	BS EN 12390-3
10.0 cm	1500, 2000, 3000 kN	700 kgf/s	BS EN 12390-3
15.0 cm	1500, 2000, 3000 kN	1600 kgf/s	BS EN 12390-3
20.0 cm	1500, 2000, 3000 kN	2800 kgf/s	BS EN 12390-3
Stress calculation $S$ (kgf/cm <sup>2</sup> ) = Peak Load (kgf) /D <sup>2</sup> (cm <sup>2</sup> )			

Imperial Units			
Size	Supporting Frames	Pace Rate	Standard
2.0 in	250, 1500, 2000 kN if dual sensor option enabled	400 lbf/s	BS EN 12390-3
3.0 in	250, 1500, 2000, 3000 kN	800 lbf/s	BS EN 12390-3
4.0 in	1500, 2000, 3000 kN	1600 lbf/s	BS EN 12390-3
6.0 in	1500, 2000, 3000 kN	3600 lbf/s	BS EN 12390-3
8.0 in	1500, 2000, 3000 kN	6400 lbf/s	BS EN 12390-3
Stress calculation $S$ (psi) = Peak Load (lbf) /D <sup>2</sup> (in <sup>2</sup> )			

### Cylinders

S.I. Units, all to BS EN 12390-3			
Diameter	Height	Supporting Frames	Pace Rate
50 mm	100 mm	250 kN	1.4 kN/s
50 mm	100 mm	1500, 2000 kN if dual sensor option enabled	1.4 kN/s
75 mm	150 mm	250, 1500, 2000, 3000 kN	3.0 kN/s
100 mm	200 mm	250, 1500, 2000, 3000 kN Pace rate limited to 5.0 kN/s on 250 is still within standard	6.0 kN/s
150 mm	150 mm	1500, 2000, 3000 kN	12.0 kN/s
150 mm	300 mm	1500, 2000, 3000 kN	12.0 kN/s
160 mm	320 mm	1500, 2000, 3000 kN	15.0 kN/s
Stress calculation $S$ (N/mm <sup>2</sup> ) = Peak Load (N) / ((D/2) <sup>2</sup> * PI) (mm <sup>2</sup> )			

Metric Units, all to BS EN 12390-3			
Diameter	Height	Supporting Frames	Pace Rate
5.0 cm	10.0 cm	250 kN	140 kgf/s
5.0 cm	10.0 cm	1500, 2000 kN if dual sensor option enabled	140 kgf/s
7.5 cm	15.0 cm	1500, 2000, 3000 kN	300 kgf/s
10.0 cm	20.0 cm	1500, 2000, 3000 kN Pace rate limited to 500 kgf/s on 250 is still within standard	600 kgf/s
15.0 cm	15.0 cm	1500, 2000, 3000 kN	1200 kgf/s
15.0 cm	30.0 cm	1500, 2000, 3000 kN	1200 kgf/s
16.0 cm	32.0 cm	1500, 2000, 3000 kN	1500 kgf/s
Stress calculation $S$ (kgf/cm <sup>2</sup> ) = Peak Load (kgf) / ((D/2) <sup>2</sup> * PI) (cm <sup>2</sup> )			

Imperial Units, all to BS EN 12390-3			
Diameter	Height	Supporting Frames	Pace Rate
2.0 in	4.0 in	250 kN	300 lbf/s
2.0 in	4.0 in	1500, 2000 kN if dual sensor option enabled	300 lbf/s
3.0 in	6.0 in	250, 1500, 2000, 3000 kN	700 lbf/s
4.0 in	8.0 in	250, 1500, 2000, 3000 kN Pace rate limited to 1100 lbf/s on 250 still within standard	1300 lbf/s
6.0 in	12.0 in	1500, 2000, 3000 kN	3000 lbf/s
Stress calculation $S$ (psi) = Peak Load (lbf) / ((D/2) <sup>2</sup> * PI (in <sup>2</sup> ))			

### Standard Tensile Cylinder Shapes

S.I. Units, all to BS EN 12390-6			
Length	Diameter	Supporting Frames	Pace Rate
150 mm	150 mm	1500, 2000, 3000 kN	2.0 kN/s
300 mm	150 mm	1500, 2000, 3000 kN	4.0 kN/s
Stress calculation $S \text{ (N/mm}^2\text{)} = \text{Peak Load (N)} * 2 / (\text{L} * \text{D} * \text{PI}) \text{ (mm}^2\text{)}$			

Metric Units, all to BS EN 12390-6			
Length	Diameter	Supporting Frames	Pace Rate
15.0 cm	15.0 cm	1500, 2000, 3000 kN	200 kgf/s
30.0 cm	15.0 cm	1500, 2000, 3000 kN	400 kgf/s
Stress calculation $S \text{ (kgf/cm}^2\text{)} = \text{Peak Load (kgf)} * 2 / (\text{L} * \text{D} * \text{PI}) \text{ (cm}^2\text{)}$			

Metric Units, all to BS EN 12390-6			
Length	Diameter	Supporting Frames	Pace Rate
6.0 in	6.0 in	1500, 2000, 3000 kN	450 lbf/s
12.0 in	6.0 in	1500, 2000, 3000 kN	900 lbf/s
Stress calculation $S \text{ (psi)} = \text{Peak Load (kgf)} * 2 / (\text{L} * \text{D} * \text{PI}) \text{ (cm}^2\text{)}$			

### Standard Block Shapes

S.I. Units					
Strength	Length	Depth	Height	Supporting Frames	Pace Rate
LO	75 mm	440 mm	215 mm	2000, 3000 kN	2.75 kN/s
LO	100 mm	440 mm	215 mm	2000, 3000 kN	3.70 kN/s
LO	140 mm	440 mm	215 mm	2000, 3000 kN	5.10 kN/s
LO	150 mm	440 mm	215 mm	2000, 3000 kN	5.50 kN/s
LO	190 mm	440 mm	215 mm	2000, 3000 kN	7.00 kN/s
LO	200 mm	440 mm	215 mm	2000, 3000 kN	7.30 kN/s
LO	215 mm	440 mm	215 mm	2000, 3000 kN	7.90 kN/s
HI	75 mm	440 mm	215 mm	2000, 3000 kN	5.50 kN/s
HI	100 mm	440 mm	215 mm	2000, 3000 kN	7.30 kN/s
HI	140 mm	440 mm	215 mm	2000, 3000 kN	10.20 kN/s
HI	150 mm	440 mm	215 mm	2000, 3000 kN	11.00 kN/s
HI	190 mm	440 mm	215 mm	2000, 3000 kN	13.90 kN/s
HI	200 mm	440 mm	215 mm	2000, 3000 kN	14.60 kN/s
HI	215 mm	440 mm	215 mm	2000, 3000 kN	15.80 kN/s
Stress calculation $S \text{ (N/mm}^2\text{)} = \text{Peak Load (N)} / (\text{L} * \text{D}) \text{ (mm}^2\text{)}$					

Metric Units					
Strength	Length	Depth	Height	Supporting Frames	Pace Rate
LO	7.5 cm	44.0 cm	21.5 cm	2000, 3000 kN	275 kgf/s
LO	10.0 cm	44.0 cm	21.5 cm	2000, 3000 kN	370 kgf/s
LO	14.0 cm	44.0 cm	21.5 cm	2000, 3000 kN	510 kgf/s
LO	15.0 cm	44.0 cm	21.5 cm	2000, 3000 kN	550 kgf/s
LO	19.0 cm	44.0 cm	21.5 cm	2000, 3000 kN	700 kgf/s
LO	20.0 cm	44.0 cm	21.5 cm	2000, 3000 kN	730 kgf/s
LO	21.5 cm	44.0 cm	21.5 cm	2000, 3000 kN	790 kgf/s
HI	7.5 cm	44.0 cm	21.5 cm	2000, 3000 kN	550 kgf/s
HI	10.0 cm	44.0 cm	21.5 cm	2000, 3000 kN	730 kgf/s
HI	14.0 cm	44.0 cm	21.5 cm	2000, 3000 kN	1020 kgf/s
HI	15.0 cm	44.0 cm	21.5 cm	2000, 3000 kN	1100 kgf/s
HI	19.0 cm	44.0 cm	21.5 cm	2000, 3000 kN	1390 kgf/s
HI	20.0 cm	44.0 cm	21.5 cm	2000, 3000 kN	1460 kgf/s
HI	21.5 cm	44.0 cm	21.5 cm	2000, 3000 kN	1580 kgf/s
Stress calculation $S \text{ (kgf/cm}^2\text{)} = \text{Peak Load (kgf)} / (\text{L} * \text{D}) \text{ (cm}^2\text{)}$					

### Standard Beam Shapes

S.I. Units, to BS 196-1 for cement testing						
Point	Length Description	Depth	Height	Supporting Frames	Pace Rate	Default Roller Separation (L)
Centre	160 mm	40 mm	40 mm	25 kN	0.05 kN/s	100 mm
Stress calculation $S \text{ (N/mm}^2\text{)} = 1.5 * \text{Peak Load (N)} * L / (D * H * H) \text{ (mm}^2\text{)}$						

S.I. Units, to BS 12390-5 for concrete testing						
Point	Length Description	Depth	Height	Supporting Frames	Pace Rate	Default Roller Separation (L)
Third	500 mm	100.0 mm	100.0 mm	100 kN	0.18 kN/s	3 * D mm
Third	508 mm	101.6 mm	101.6 mm	100 kN	0.19 kN/s	3 * D mm
Third	750 mm	150.0 mm	150.0 mm	100 kN	0.40 kN/s	3 * D mm
Third	762 mm	152.4 mm	152.4 mm	100 kN	0.41 kN/s	3 * D mm
Third	800 mm	200.0 mm	200.0 mm	100 kN	0.70 kN/s	3 * D mm
Stress calculation $S \text{ (N/mm}^2\text{)} = \text{Peak Load (N)} * L / (D * H * H) \text{ (mm}^2\text{)}$ , for Third Point						
Stress calculation $S \text{ (N/mm}^2\text{)} = 1.5 * \text{Peak Load (N)} * L / (D * H * H) \text{ (mm}^2\text{)}$ for Centre Point						

Metric Units, to BS 196-1 for cement testing						
Point	Length Description	Depth	Height	Supporting Frames	Pace Rate	Default Roller Separation (L)
Centre	16.0 cm	4.0 cm	4.0 cm	25 kN	5 kgf/s	10 cm
Stress calculation $S \text{ (kg/cm}^2\text{)} = 1.5 * \text{Peak Load (kg)} * L / (D * H * H) \text{ (cm}^2\text{)}$						

Metric Units, to BS 12390-5 for concrete testing						
Point	Length Description	Depth	Height	Supporting Frames	Pace Rate	Default Roller Separation (L)
Third	50 cm	10.0 cm	10.0 cm	100 kN	18 kgf/s	3 * D cm
Third	51 cm	10.2 cm	10.2 cm	100 kN	19 kgf/s	3 * D cm
Third	75 cm	15.0 cm	15.0 cm	100 kN	40 kgf/s	3 * D cm
Third	76 cm	15.2 cm	15.2 cm	100 kN	41 kgf/s	3 * D cm
Third	80 cm	20.0 cm	20.0 cm	100 kN	70 kgf/s	3 * D cm
Stress calculation $S \text{ (kg/cm}^2\text{)} = \text{Peak Load (kg)} * L / (D * H * H) \text{ (cm}^2\text{)}$ , for Third Point						
Stress calculation $S \text{ (kg/cm}^2\text{)} = 1.5 * \text{Peak Load (kg)} * L / (D * H * H) \text{ (cm}^2\text{)}$ for Centre Point						

### Standard Kerb Shapes

Stress is not calculated for Kerbs, Channels and Type R and S Blocks.

S.I. Units, to BS EN 1340:2003				
Description	Depth	Height	Supporting Frames	Pace Rate
HALF BATTERED HB1	305.0 mm	150.0 mm	100 kN	0.25 kN/s
HALF BATTERED HB2	255.0 mm	125.0 mm	100 kN	0.40 kN/s
HALF BATTERED HB3	150.0 mm	125.0 mm	100 kN	0.65 kN/s
TRANSITION RIGHT TR	255.0 mm	125.0 mm	100 kN	0.40 kN/s
TRANSITION LEFT TL	255.0 mm	125.0 mm	100 kN	0.40 kN/s
DROPPER RIGHT DR1	255.0 mm	125.0 mm	100 kN	0.40 kN/s
DROPPER RIGHT DR2	255.0 mm	125.0 mm	100 kN	0.40 kN/s
DROPPER LEFT DL1	255.0 mm	125.0 mm	100 kN	0.40 kN/s
DROPPER LEFT DL2	255.0 mm	125.0 mm	100 kN	0.40 kN/s
BULLNOSED BN	150.0 mm	125.0 mm	100 kN	0.65 kN/s
SPLAYED SP	255.0 mm	125.0 mm	100 kN	0.40 kN/s

Metric Units, to BS EN 1340:2003				
Description	Depth	Height	Supporting Frames	Pace Rate
HALF BATTERED HB1	30.5 cm	15.0 cm	100 kN	25 kgf/s
HALF BATTERED HB2	25.0 cm	12.5 cm	100 kN	40 kgf/s
HALF BATTERED HB3	15.0cm	12.5 cm	100 kN	65 kgf/s
TRANSITION RIGHT TR	25.5 cm	12.5 cm	100 kN	40 kgf/s
TRANSITION LEFT TL	25.5 cm	12.5 cm	100 kN	40 kgf/s
DROPPER RIGHT DR1	25.5 cm	12.5 cm	100 kN	40 kgf/s
DROPPER RIGHT DR2	25.5 cm	12.5 cm	100 kN	40 kgf/s
DROPPER LEFT DL1	25.5 cm	12.5 cm	100 kN	40 kgf/s
DROPPER LEFT DL2	25.5 cm	12.5 cm	100 kN	40 kgf/s
BULLNOSED BN	15.0 cm	12.5 cm	100 kN	65 kgf/s
SPLAYED SP	25.5 cm	12.5 cm	100 kN	40 kgf/s

### Standard Flag Shapes

S.I. Units, to BS EN 1339:2003						
Description	Point	Depth	Height	Supporting Frames	Pace Rate	Default Roller Separation (L)
A 600 x 450 x 50 mm	Centre	450.0 mm	50.0 mm	100 kN	0.16 kN/s	550 mm
A 600 x 450 x 63 mm	Centre	450.0 mm	63.0 mm	100 kN	0.20 kN/s	550 mm
B 600 x 600 x 50 mm	Centre	600.0 mm	50.0 mm	100 kN	0.21 kN/s	550 mm
B 600 x 600 x 63 mm	Centre	600.0 mm	63.0 mm	100 kN	0.26 kN/s	550 mm
C 750 x 600 x 50 mm	Centre	600.0 mm	50.0 mm	100 kN	0.21 kN/s	700 mm
C 750 x 600 x 63 mm	Centre	600.0 mm	63.0 mm	100 kN	0.26 kN/s	700 mm
D 900 x 600 x 50 mm	Centre	600.0 mm	50.0 mm	100 kN	0.21 kN/s	850 mm
D 900 x 600 x 63 mm	Centre	600.0 mm	63.0 mm	100 kN	0.26 kN/s	850 mm
E 450 x 450 x 50 mm	Centre	450.0 mm	50.0 mm	100 kN	0.16 kN/s	400 mm
E 450 x 450 x 63 mm	Centre	450.0 mm	63.0 mm	100 kN	0.11 kN/s	400 mm
F 400 x 400 x 50 mm	Centre	400.0 mm	50.0 mm	100 kN	0.14 kN/s	350 mm
F 400 x 400 x 63 mm	Centre	400.0 mm	63.0 mm	100 kN	0.18 kN/s	350 mm
G 300 x 300 x 50 mm	Centre	300.0 mm	50.0 mm	100 kN	0.10 kN/s	250 mm
G 300 x 300 x 63mm	Centre	300.0 mm	63.0 mm	100 kN	0.13 kN/s	250 mm
Stress calculation $S$ (N/mm <sup>2</sup> ) = 1.5 * Peak Load (N) * L / (D * H * H) (mm <sup>2</sup> ) for Centre Point						

Metric Units, to BS EN 1339:2003						
Description	Point	Depth	Height	Supporting Frames	Pace Rate	Default Roller Separation (L)
A 60 x 45 x 5 cm	Centre	45.0 cm	5.0 cm	100 kN	16 kgf/s	55 cm
A 60 x 45 x 6.3 cm	Centre	45.0 cm	6.3 cm	100 kN	20 kgf/s	55 cm
B 60 x 60 x 5 cm	Centre	60.0 cm	5.0 cm	100 kN	21 kgf/s	55 cm
B 60 x 60 x 6.3 cm	Centre	60.0 cm	6.3 cm	100 kN	26 kgf/s	55 cm
C 75 x 60 x 5 cm	Centre	60.0 cm	5.0 cm	100 kN	21 kgf/s	70 cm
C 75 x 60 x 6.3 cm	Centre	60.0 cm	6.3 cm	100 kN	26 kgf/s	70 cm
D 90 x 60 x 5 cm	Centre	60.0 cm	5.0 cm	100 kN	21 kgf/s	85 cm
D 90 x 60 x 6.3 cm	Centre	60.0 cm	6.3 cm	100 kN	26 kgf/s	85 cm
E 45 x 45 x 5 cm	Centre	45.0 cm	5.0 cm	100 kN	16 kgf/s	40 cm
E 45 x 45 x 6.3 cm	Centre	45.0 cm	6.3 cm	100 kN	11 kgf/s	40 cm
F 40 x 40 x 5 cm	Centre	40.0 cm	5.0 cm	100 kN	14 kgf/s	35 cm
F 40 x 40 x 6.3 cm	Centre	40.0 cm	6.3 cm	100 kN	18 kgf/s	35 cm
G 30 x 30 x 5 cm	Centre	30.0 cm	5.0 cm	100 kN	10 kgf/s	25 cm
G 30 x 30 x 6.3 cm	Centre	30.0 cm	6.3 cm	100 kN	13 kgf/s	25 cm
Stress calculation $S$ (kgf/cm <sup>2</sup> ) = 1.5 * Peak Load (kgf) * L / (D * H * H) (cm <sup>2</sup> ) for Centre Point						



### Standard Brick Shapes

S.I. Units				
Length	Depth	Height	Supporting Frames	Pace Rate
215.0 mm	102.0 mm	65.0 mm	1500, 2000, 3000 kN	14.8 kN/s
215.0 mm	102.0 mm	75.0 mm	1500, 2000, 3000 kN	14.8 kN/s
200.0 mm	100.0 mm	75.0 mm	1500, 2000, 3000 kN	13.7 kN/s
200.0 mm	100.0 mm	105.0 mm	1500, 2000, 3000 kN	13.7 kN/s

Metric Units				
Length	Depth	Height	Supporting Frames	Pace Rate
21.5 cm	10.2 cm	6.5 cm	1500, 2000, 3000 kN	1480 kgf/s
21.5 cm	10.2 cm	7.5 cm	1500, 2000, 3000 kN	1480 kgf/s
20.0 cm	10.0 cm	7.5 cm	1500, 2000, 3000 kN	1370 kgf/s
20.0 cm	10.0 cm	10.5 cm	1500, 2000, 3000 kN	1370 kgf/s

### Standard Channel Shapes

S.I. Units				
Description	Depth	Height	Supporting Frames	Pace Rate
ROUND TOP (ER)	200.0 mm	50.0 mm	100 kN	0.25 kN/s
ROUND TOP (ER)	250.0 mm	50.0 mm	100 kN	0.40 kN/s
FLAT TOP (EF)	150.0 mm	50.0 mm	100 kN	0.20 kN/s
FLAT TOP (EF)	250.0 mm	50.0 mm	100 kN	0.40 kN/s

Metric Units				
Description	Depth	Height	Supporting Frames	Pace Rate
ROUND TOP (ER)	20.0 cm	5.0 cm	100 kN	25 kgf/s
ROUND TOP (ER)	25.0 cm	5.0 cm	100 kN	40 kgf/s
FLAT TOP (EF)	15.0 cm	5.0 cm	100 kN	20 kgf/s
FLAT TOP (EF)	25.0 cm	5.0 cm	100 kN	40 kgf/s

**Standard Aggregate Sizes**

S.I. Units to BS 812		
Description	Supporting Frames	Pace Rate
ACV 5/3.35 mm	1500, 2000, 3000 kN	0.65 kN/s
ACV 3.35/2.36 mm	1500, 2000, 3000 kN	0.65 kN/s
ACV 28/20 mm	1500, 2000, 3000 kN	0.65 kN/s
ACV 20/14 mm	1500, 2000, 3000 kN	0.65 kN/s
ACV 14/10 mm	1500, 2000, 3000 kN	0.65 kN/s
ACV 10/6.3 mm	1500, 2000, 3000 kN	0.65 kN/s
ACV 6.3/5 mm	1500, 2000, 3000 kN	0.65 kN/s
TFV RNDED/UNCRUSH	1500, 2000, 3000 kN	0.65 kN/s
TFV CRUSHED	1500, 2000, 3000 kN	0.65 kN/s
TFV VESICULAR	1500, 2000, 3000 kN	0.65 kN/s

Metric Units to BS 812		
Description	Supporting Frames	Pace Rate
ACV 0.5/0.33 cm	1500, 2000, 3000 kN	66 kgf/s
ACV 0.33/0.24 cm	1500, 2000, 3000 kN	66 kgf/s
ACV 2.8/2.0 cm	1500, 2000, 3000 kN	66 kgf/s
ACV 2.0/1.4 cm	1500, 2000, 3000 kN	66 kgf/s
ACV 1.4/1.0 cm	1500, 2000, 3000 kN	66 kgf/s
ACV 1.0/0.63 cm	1500, 2000, 3000 kN	66 kgf/s
ACV 0.63/0.5 cm	1500, 2000, 3000 kN	66 kgf/s
TFV RNDED/UNCRUSH	1500, 2000, 3000 kN	66 kgf/s
TFV CRUSHED	1500, 2000, 3000 kN	66 kgf/s
TFV VESICULAR	1500, 2000, 3000 kN	66 kgf/s

## Sample Types and Sizes: Accu-Tek Range to ASTM C39/C78M/C109

### Standard Cube Sizes

S.I. Units			
Size	Supporting Frames	Pace Rate	Standard
50 mm	Accu-Tek 250, 350, 500	1.5 kN/s	ASTM C109
150 mm	Accu-Tek 250, 350, 500	13.5 kN/s	ASTM
Stress calculation $S \text{ (N/mm}^2\text{)} = \text{Peak Load (N)} / D^2 \text{ (mm}^2\text{)}$			

Metric Units			
Size	Supporting Frames	Pace Rate	Standard
5.0 cm	Accu-Tek 250, 350, 500	150 kgf/s	ASTM C109
15.0 cm	Accu-Tek 250, 350, 500	1350 kgf/s	ASTM
Stress calculation $S \text{ (kgf/cm}^2\text{)} = \text{Peak Load (kgf)} / D^2 \text{ (cm}^2\text{)}$			

Imperial Units			
Size	Supporting Frames	Pace Rate	Standard
2.0 in	Accu-Tek 250, 350, 500	340 lbf/s	ASTM C109
6.0 in	Accu-Tek 250, 350, 500	3000 lbf/s	ASTM
Stress calculation $S \text{ (psi)} = \text{Peak Load (lbf)} / D^2 \text{ (in}^2\text{)}$			

### Standard Cylinder Shapes

Imperial Units, all to ASTM C39			
Diameter	Height	Supporting Frames	Pace Rate
2.0 in	4.0 in	Accu-Tek 250, 350, 500	120 lbf/s
3.0 in	6.0 in	Accu-Tek 250, 350, 500	280 lbf/s
4.0 in	8.0 in	Accu-Tek 250, 350, 500	500 lbf/s
6.0 in	12.0 in	Accu-Tek 250, 350, 500	1100 lbf/s
Stress calculation $S \text{ (psi)} = \text{Peak Load (lbf)} / ((D/2)^2 * \text{PI (in}^2\text{)})$			

### Standard Block Shapes

Imperial Units, all to ASTM					
Strength	Length	Depth	Height	Supporting Frames	Pace Rate
LO	4.0 in	16.0 in	8.0 in	2000, 3000 kN	800 lbf/s
LO	6.0 in	16.0 in	8.0 in	2000, 3000 kN	1000 lbf/s
LO	8.0 in	16.0 in	8.0 in	2000, 3000 kN	1500 lbf/s
LO	10.0 in	16.0 in	8.0 in	2000, 3000 kN	2000 lbf/s
LO	12.0 in	16.0 in	8.0 in	2000, 3000 kN	2500 lbf/s
HI	4.0 in	16.0 in	8.0 in	2000, 3000 kN	1500 lbf/s
HI	6.0 in	16.0 in	8.0 in	2000, 3000 kN	2000 lbf/s
HI	8.0 in	16.0 in	8.0 in	2000, 3000 kN	3000 lbf/s
HI	10.0 in	16.0 in	8.0 in	2000, 3000 kN	4000 lbf/s
HI	12.0 in	16.0 in	8.0 in	2000, 3000 kN	5000 lbf/s
Stress calculation $S$ (psi) = Peak Load (lbf) / (L * D) (in <sup>2</sup> )					

### Standard Beam Shapes

Imperial Units, to ASTM C78M-15a concrete testing						
Point	Length Description	Depth	Height	Supporting Frames	Pace Rate	Default Roller Separation (L)
Third	15 in	4.0 in	4.0 in	Accu-Tek 250, 300, 500	14 lbf/s	3 * D in
Third	21 in	6.0 in	6.0 in	Accu-Tek 250, 300, 500	32 lbf/s	3 * D in
Third	24 in	6.0 in	6.0 in	Accu-Tek 250, 300, 500	32 lbf/s	3 * D in
Third	30 in	6.0 in	6.0 in	Accu-Tek 250, 300, 500	32 lbf/s	3 * D in
Third	36 in	6.0 in	6.0 in	Accu-Tek 250, 300, 500	32 lbf/s	3 * D in
Stress calculation $S$ (psi) = Peak Load (lbf) * L / (D * H * H) (cm <sup>2</sup> ), for Third Point						
Stress calculation $S$ (psi) = 1.5 * Peak Load (lbf) * L / (D * H * H) (cm <sup>2</sup> ) for Centre Point						

## Appendix 2: Pace Rate Limits

Depending on the load frame currently in use, the ADR Touch Control PRO limits the range of pace rates that can be entered. These are shown in the following table:

Load Frame	Range (kN/sec)	Range (lbf/sec)	Range (kgf/sec)
<b>25 kN</b>	0.5	112	50
<b>100 kN</b>	2.0	450	200
<b>250 kN</b>	5.0	1124	500
<b>2000 kN</b>	30	6700	3000
<b>3000 kN</b>	30	6700	3000

## Appendix 3: Printout Formats

The following shows a typical printout for a cube:

### **Cube**

```

Serial Number   - 1939-1-10045
Operating Mode  - 1:Compression
Date            - 10/10/2017
Time           - 10:25:33
Sample Group    - TESTS
Sample Ref      - 00000001
Sample Type     - Cube
Sample Units    - S.I.
Maximum Load    - 954.50kN
Pace Rate       - 13.50kN/Sec
Stress          - 42.41 MPa (N/mm2)
Sample Height   - 150.00mm
Sample Width    - 150.00mm
Sample Depth    - 150.00mm
Weight in Air   - 8100.00g
Weight in Water - 4725.00g
Sample Density  - 2395.69kg/m3
Failure Type    - 0
Sample Age      - 0
Stopped due to  - Failure
  
```

The exact format of the printout depends on the sample type under test and the data values inputted.

#### Appendix 4: Results File Formats

An example results file is given below:

Column Number	Description	Example data
1	Ref	ELETestREF001
2	Date	23/11/2017
3	Time	13:04
4	Mode	1
5	Frame Type	0
6	S/N	1939-1-10003
7	Group	TESTS
8	Units	0
9	Peak Load	447.7
10	Peak Stress	19.9
11	Pace Rate	16
12	Shape	0
13	Dimension-1	150
14	Dimension-2	150
15	Dimension-3	150
16	Weight in Air	0
17	Weight in Water	0
18	Density	0
19	Separation	0
20	Time to max. load	125
21	Hardware	1
22	Firmware	ADR-Auto V1.00.00 21-Nov-17 20:00:00
23	Stop Reason	16
24	Flex Mode	
25	Failure Type	0
26	Sample Age	0
27	Time (s)	Load (kN)
28	0	15.5
29	0.25	17
30	0.5	17.4
31	0.75	17.7
32	1	17.9
33	1.25	18.2
34	1.5	18.4
35	1.75	18.8
36	2	19
N	Timestamp	Encryption code

The maximum length of the file is defined by the maximum sampling time of 1 hour and sampling frequency of 4 Hz. Therefore, the file may be  $27 + (4 \times 3600) + 1$ , that is 14428 rows.

The data may be of the form:

Ref	up to 16 characters
Date	DD/MM/YYYY or MM/DD/YYYY depending on date format
Time	HH:MM
Mode	1 or 2, depending on selected frame for test
Frame Type	0 for compression, 1 for flexural
S/N	typically of the form NNNN-N-NNNNN
Group	8 character folder name
Units	0 for S.I. 1 for US/Imperial, 2 for Metric
Peak Load	value in kN
Peak Stress	value in MPa
Pace Rate	value in kN/s
Shape	value 0-9, see shape code below
Dimension-1	dimension in mm
Dimension-2	dimension in mm
Dimension-3	dimension in mm
Weight in Air	0 or weight in kg
Weight in Water	0 or weight in kg
Density	0 or density in kg/m <sup>3</sup>
Separation	dimension in mm
Time to max. load	time is seconds
Hardware	a value 1 to 9
Firmware	Extended firmware description, see above example
Stop Reason	N-NN, see stop code below
Flex Mode	Blank space, Centre Point, or Third Point
Failure Type	Currently set to 0, but may be 0-99 in future releases
Sample Age	Currently set to 0, but may be 0-99 age in days of the sample
Time (s)	Load (kN)
Time in 0.25 second intervals	Load (kN)
Continues until last sample	
Timestamp	File encryption code





































Shape code	Sample Type
0	Cube
1	Cylinder
2	Cylinder - Tensile
3	Beam
4	Block
5	Kerb
6	Flagstone
7	Brick
8	Channel
9	Aggregate













---

Stop Code	Stop Reason
0	Sample break detected
1	Reached test limit
2	Data acquisition buffer is full
3	Force overload (frame limit)
4	Valve fault occurred
5	Load was above close threshold prior to ADR Auto tare
6	Load was above the tare limit prior to ADR Auto tare
7	Sensor read fault occurred
8	Low voltage sensor detected
9	E-Stop was pressed
10	Interlock activated
11	Safety input activated
12	Fault with the E-Stop/Interlock/Safety protection inputs
13	Invalid test conditions
14	PID control fault has occurred
15	Test stopped by remote user
16	Test stopped by user
17	Test stopped after holding in dual pace rate mode



### Appendix 5: Glossary of Icons

	Home		Sample Types		Saved Data
	Accept/Enter		Add		Test Setup
	Print		Calibration/ Protected Area		Settings
	Folder		Pause		Run
	Minus (Small Increment)		Minus (Large Increment)		Edit
	Plus (Small Increment)		Plus (Large Increment)		Test Stop
	Scroll Left		Scroll Right		Scroll Down
	Scroll Up		Main Pump (Static)		Main Pump (In Operation)
	Warning		Rapid Approach Pump (Static)		Rapid Approach Pump (In Operation)
	Delete		Reset		USB Connection
	Compression		Flexural		Favourite (Unselected)
	Favourite (Selected)		Zoom		Weight

	Cube		Cylinder		Cylinder (Transverse)
	Beam		Block		Flagstone
	Aggregate		Bricks		Kerbstone
	Channel		4 Point Flexural		3 Point Flexural

**Appendix 6: Troubleshooting Guide**

<b>SYMPTOM</b>	<b>PROBLEM</b>	<b>SOLUTION</b>
No display showing	No power	Check power supply
	Screen brightness set too low	Adjust brightness
	Cables loose	Check cables are secure to the ADR Touch Control Pro
Machine not operating	Emergency stop activated	Check emergency stop
	Interlock engaged	Check interlock, shut door
	Frame connection loose at rear of console	Refit frame connection to console
	Ram switch engaged	Check ram switch
	Debris not cleared from previous tests	Check for debris around switches
Results not saving	Auto Save flag not set	Set flag
	Memory card full	Clear results log/Replace SD card
	SD card missing or failed	Fit/replace SD card
“ADR Range” showing on display	Cables loose or missing from ADR Touch Control PRO	Fit/tighten large cable
	Power board failure	Replace power board
Machine running but no pressure building up	Dump valve not operating correctly	Check fuse
	Dump valve leaking internally	Perform Dump Valve leak check
	Pressure Relief Valve opened	Perform Pressure Relief Valve leak check
	External hydraulic leak	Check for leaks at hoses/fittings
	Main motor not running	Check fuse and voltage at connector

<b>SYMPTOM</b>	<b>PROBLEM</b>	<b>SOLUTION</b>
Second frame not working	Incorrect mode selected	Select correct mode
	Changeover valve not operating	Check fuse
	Manual changeover valve not correctly selected	Select correct position
	Air in hydraulic system	Bleed hydraulic system
Valve Position Error showing	Stepper motor not reset to origin	Check stepper motor position
	Stepper motor out of sequence	Power cycle machine
	Stepper motor cable loose	Remove/Refit stepper cable
Sensor Volts Low showing	Pressure transducer not connected	Check transducer connection
Main pump motor noisy	Low oil level	Check/Top up oil
	Air in hydraulic system	Bleed hydraulic system
Daylight gap not closing	Rapid approach pump not running	Check fuse and voltage at connector
Ram not moving/Moving erratically	Air in hydraulic system	Bleed hydraulic system
Failure not recognised	Failure thresholds not met	Adjust settings
Failure mode not correct	Ball seat assembly not functioning correctly	Check ball seat
No results displayed	Failure thresholds not met	Adjust settings
	Memory card full	Clear results log/Replace SD card

**Appendix 7: Menu Tree**

<b>Settings</b>		
General Settings	- Set Date & Time - Set Language - Set Units - Display Version - Save Log	
Select Mode and Pace		
Sample Failure Settings	- Failure Level - Failure Threshold - Zero Suppress - Tare Limit - Close Threshold and Control	
Verify Mode		
User Defined Settings	- Folder for Tests - Test Data Settings - Pace Bar Width - Comms Port Settings - Adjust Display	- Clear System Errors
<b>Test Data</b>		
Daily Folder	- Test Folder	
<b>Sample Types</b>		
Select Sample Type	- Select Sample Size	
<b>Test Setup</b>		
Sample Density Pace Rate Sample Size Test Run	- Weight in Air	- Weight in Water

## Appendix 8: Error Codes

Error Code	Description
0	Operation successful
1	A hard error occurred in the low level disk I/O layer
2	Assertion failed
3	The physical drive cannot work
4	Could not find the file
5	Could not find the path
6	The path name format is invalid
7	Access denied due to prohibited access or directory full
8	Access denied due to prohibited access
9	The file/directory object is invalid
10	The physical drive is write protected
11	The logical drive number is invalid
12	The volume has no work area
13	There is no valid FAT volume
14	The creation of a FAT volume aborted due to parameter error
15	Could not get a grant to access the volume within defined period
16	The operation is rejected according to the file sharing policy
17	LFN working buffer could not be allocated
18	Number of open files > _FS_SHARE
19	Given parameter is invalid
25	SD-card is not present
26	SD-card error (generic)
27	SD-card full
28	Invalid path specified
29	Invalid filename specified
30	Specified number of bytes were not written to SD-card
31	File too big to load into internal buffer
32	File size is 0
33	Error closing file on SD-Card
34	Error reading configuration
35	Error writing configuration
36	I2C read error on primary I2C port (ADC + backlight)
37	I2C write error on primary I2C port (ADC + backlight)
38	I2C read error on secondary I2C port (touchscreen)
39	I2C write error on secondary I2C port (touchscreen)
40	Sensor calibration data is invalid
41	Sensor channel is disabled
42	Sensor voltage is below the allowable value
43	Sensor calibration data is not verified
44	Invalid ADC channel setting

45	Invalid gain setting
46	Invalid filter setting
47	HAL operation timed out
48	HAL resource is busy
49	HAL operation resulted in an error
50	Specified day folder doesn't exist or can't be read
51	Invalid test result file
52	Test is uninitialised
53	A test is in progress
54	No test in progress
55	Not enough space on SD-card
56	Unable to increment the test reference string
57	Frame data is corrupt
58	Invalid frame / sensor specified
59	Frame limit has been reached
60	Log is corrupt
61	Error setting real-time clock
62	Printer transmit error
63	No printer ACK received
64	Touch screen controller fault
65	Currently finding the control valve home position
66	The control valve isn't in the home position
67	Can't find the control valve home position
68	Control valve not initialised
69	Invalid control valve position commanded
70	Valve position is already being controlled
71	Timed out moving to valve position
72	Control valve position has gone -ve which should never happen
73	Control valve appears to be stuck
74	Control valve is not in position tracking mode
75	Control valve can't be stopped (inter-thread communication fault)
76	Load exceeds tare limit
77	Machine in error state (can't start test)
78	E-Stop is pressed
79	Interlock input is active
80	Safety input is active
81	E-Stop/Interlock/Safety input protection hardware fault
82	Can't stop valve
83	Invalid CRC
84	Command parameter 1 invalid
85	Command parameter 2 invalid
86	Command parameter 3 invalid
87	Command parameter 4 invalid

88	Command parameter 5 invalid
89	Command parameter 6 invalid
90	Comms timeout
91	No connection
92	Generic comms fault
93	EEPROM comms fault
94	EEPROM CRC fault
95	EEPROM write failed
96	EEPROM verification failed
97	The home screen is not being displayed
98	Timed out waiting for an event to occur
99	Unable to initialise system
100	The resource is locked by another threadID
101	Unit was reset due to an internal error
102	Generic internal fault
103	Internal inter-threadID comms error
104	Feature is not implemented
105	Invalid pace rate
106	No separation has been specified for a beam test
107	Test results are currently being saved
108	An invalid test folder was specified
109	Unknown command, firmware/logger mismatch
110	Invalid number of command parameters, firmware/logger mismatch
111	Generic busy error e.g. result files being scanned, file being saved, etc
200	Operation OK
201	Command response received (but CRC check failed)
202	Data block sent/received (CRC check failed)
203	Command response timeout
204	Data timeout
205	Transmit FIFO underrun
206	Receive FIFO overrun
207	Start bit not detected on all data signals
208	Command's argument was out of range.
209	Misaligned address
210	Tx block length not allowed or != tx length
211	An error in the sequence of erase command occurs.
212	An invalid selection for erase groups
213	Attempt to program a write protect block
214	Sequence or password error in unlock command
215	CRC check of the previous command failed
216	Command is not legal for the card state
217	Internal ECC was applied but failed to correct the data
218	Internal card controller error



---

219	General or unknown error
220	Could not sustain data transfer in stream read operation.
221	Could not sustain data programming in stream mode
222	CID/CSD overwrite error
223	Only partial address space was erased
224	Command has been executed without using internal ECC
225	Erase sequence cleared before executing
226	Error in sequence of authentication.
227	Invalid voltage range
228	Address out of range
229	Switch error
230	SDIO disabled
231	SDIO function busy
232	SDIO function failed
233	SDIO unknown function
234	Internal error
235	Not configured
236	Request pending
237	Request not applicable
238	Invalid parameter
239	Unsupported feature
240	Unsupported hardware
241	Generic error

## Appendix 9: ADR to ELE Logger P2P Connection

Make an RJ45 Ethernet connection between the PC and the ADR Touch Control PRO. Access the Control Panel of the PC.

**For Windows 7 PCs:** follow the instructions and screen shots below for Windows 7 PCs.

Select Network and Sharing Centre.

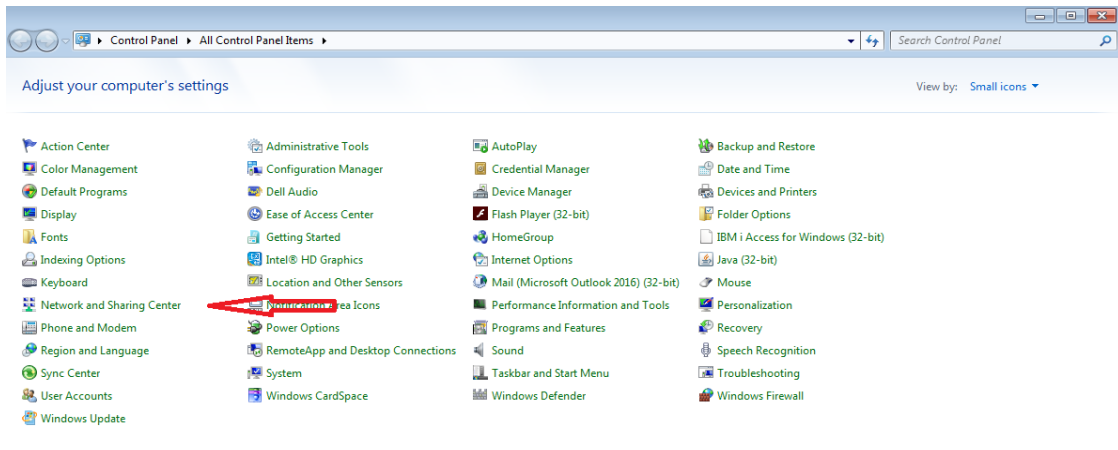

Select the LAN Connection option. If none is shown, check that the Ethernet cable between the PC and the ADR Touch Control PRO has been connected.

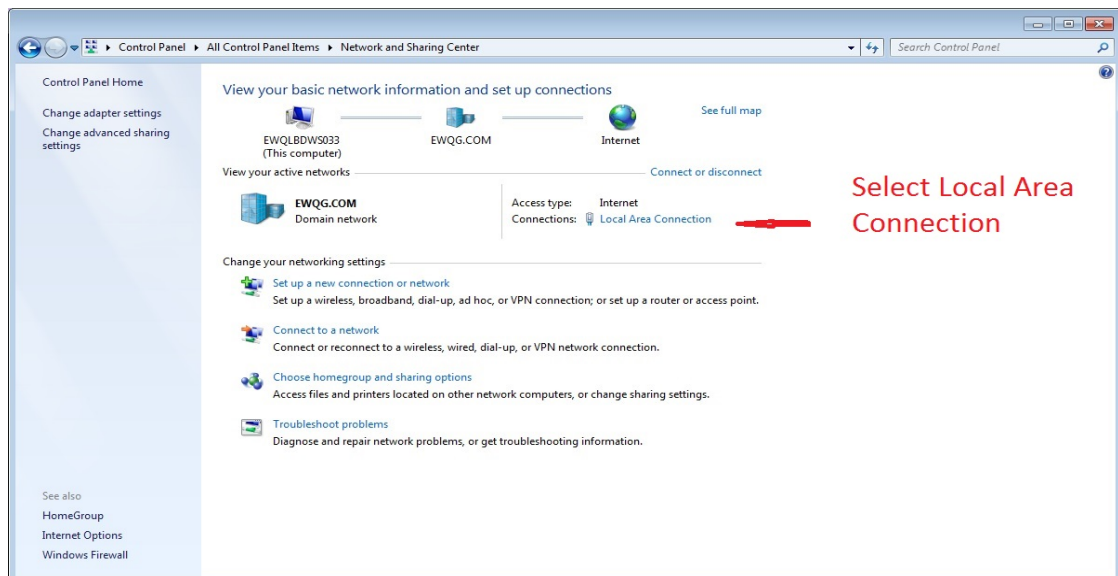

## Select Properties.

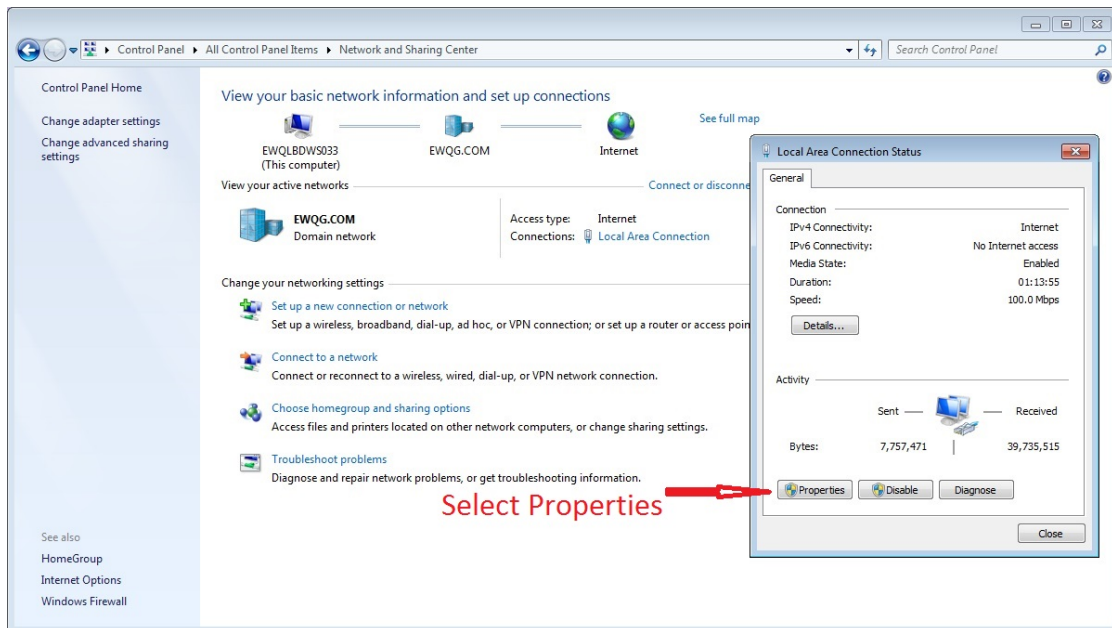

## Select Properties for Internet Protocol Version 4 (TCP/IPv4).

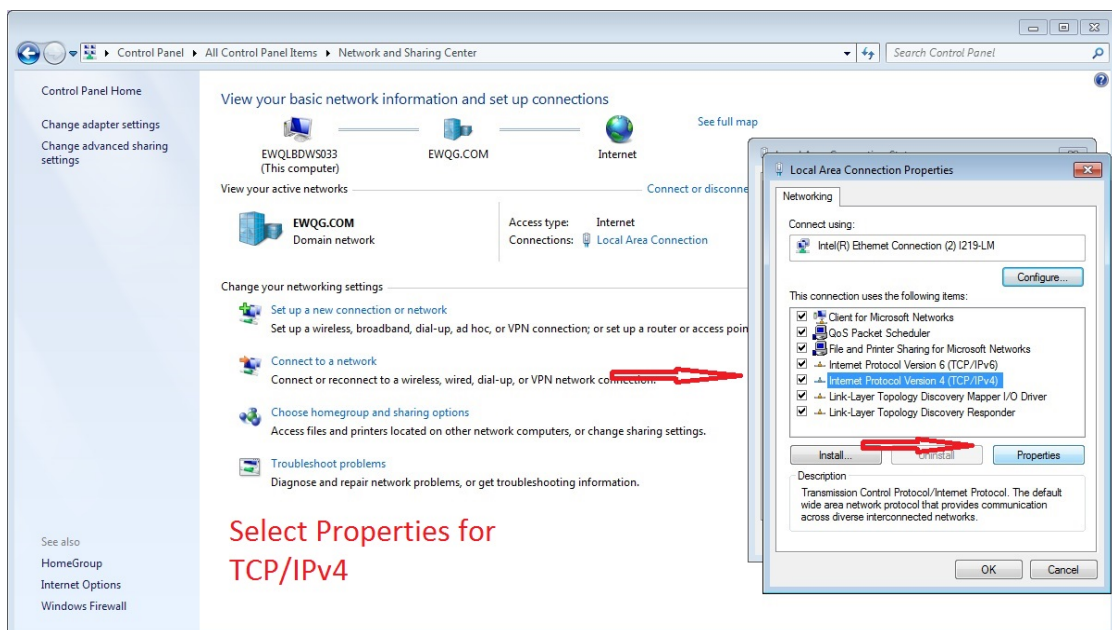

Set the following parameters:  
Select 'Use the following IP Address'.

The IP address of the PC can be almost anything but an arbitrary value of 192.168.0.100 is chosen.

The Subnet mask should be 255.255.255.0.

The Default Gateway and DNS server address should be 192.168.0.1. This setting is based on the original IP address selected.

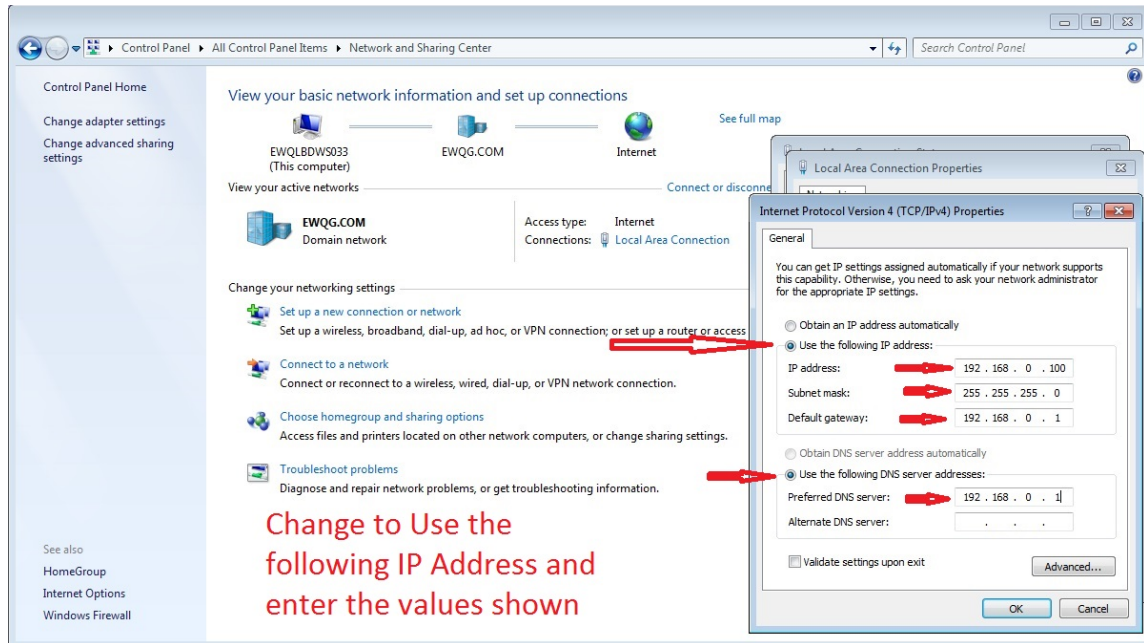

Select OK when the values have been entered and then close and exit.

**For Windows 10 PCs:** follow the instructions and screen shots below for Windows 10 PCs.

Follow the instructions below, the screen shots are taken from a Windows 10 PC.

Right click the Start button and Select Network Connections.

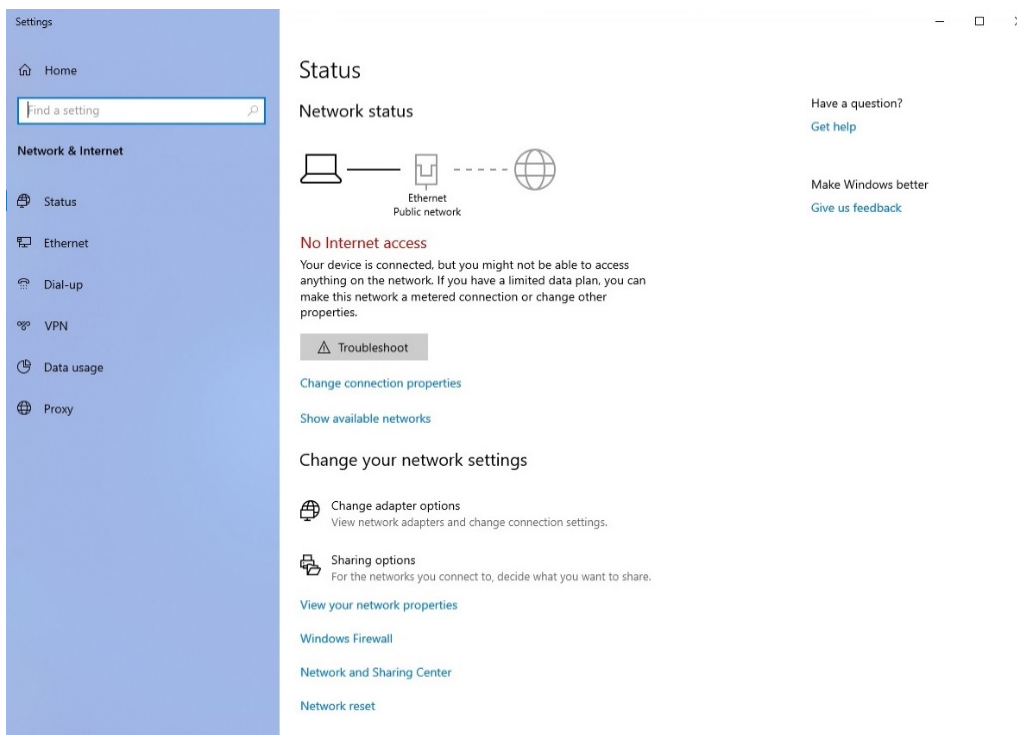

Select the Change adaptor options.

Then Right click on the network and select properties.

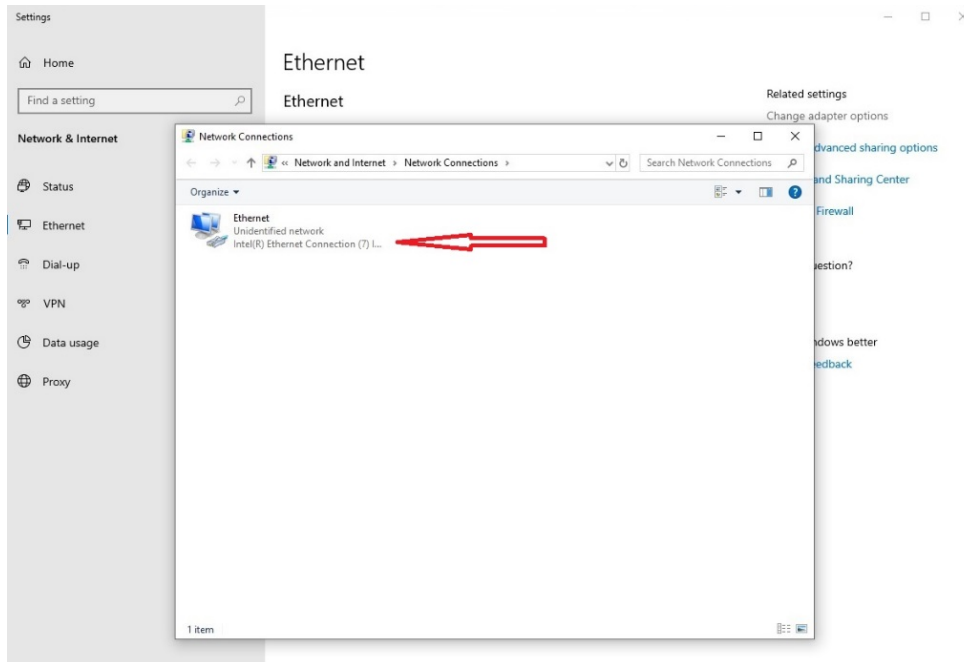

Select Internet Protocol Version 4 (TCP/IPv4) and then click on Properties.

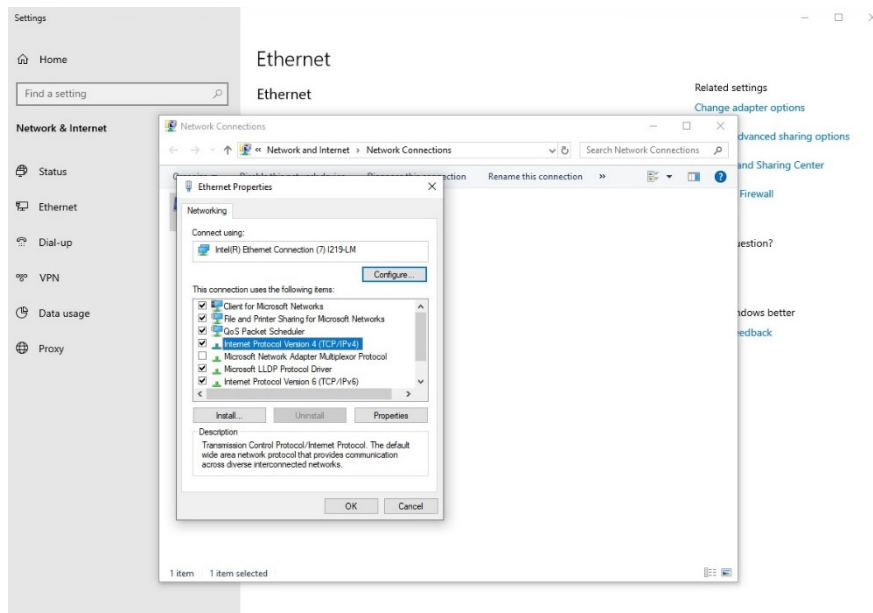

Set the following parameters:

Select 'Use the following IP Address'.

The IP address of the PC can be almost anything but an arbitrary value of 192.168.0.100 is chosen.

The Subnet mask should be 255.255.255.0.

The Default Gateway and DNS server address should be 192.168.0.1. This setting is based on the original IP address selected.

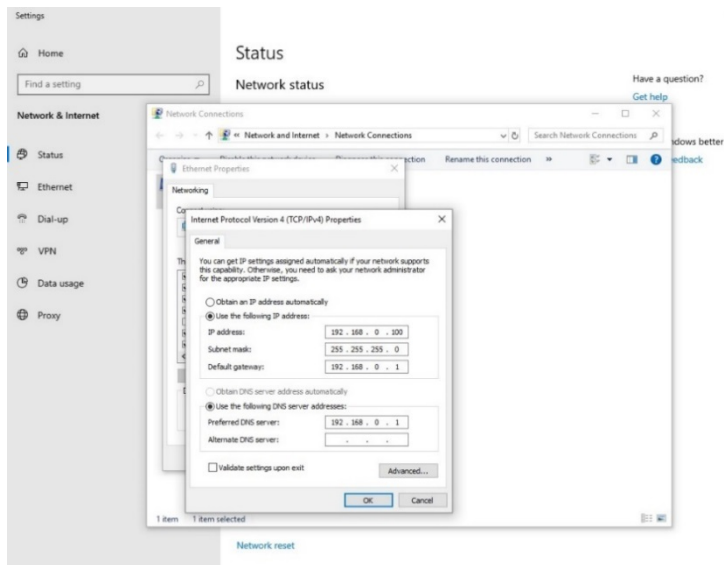

Select OK when the values have been entered and then close and exit.

## EC DECLARATION OF CONFORMITY



The Original Declaration of Conformity is suitable to Decision No 768/2008/EC of the European Parliament and the Council of 9<sup>th</sup> July 2008 on a common framework for the marketing of products and contains the elements specified in the relevant modules set out in Annex II of that Decision for the applicable Directives.

This declaration relates exclusively to the equipment in the state in which it was placed on the market, and excludes components which are added and/or operations carried out subsequently by the final user.

### Applied Council Directive(s)

2006/42/EC Machinery Directive

2014/30/EU Electromagnetic Compatibility (EMC)

2011/65/EU RoHS2 Directive and Commission Delegated Directive (EU)2015/863

have been demonstrated

We, the Manufacturer :

**ELE International**, Chartmoor Road, Chartwell Business Park, Leighton Buzzard  
Bedfordshire LU7 4WG, UK

declare under our sole responsibility that the following equipment

**Product:** ADR Touch Control PRO Range

**Catalogue Numbers:** 36-4131/nn, 36-5125/nn, 36-5150/nn, 36-5151/nn, 36-5155/nn  
36-5165/nn, 36-5170/nn, 37-4881/nn, 39-7160/nn

**Description:** Compression frame for concrete/cement/aggregate sample testing

The object of the declaration described above, is in conformity with the relevant Union Harmonisation Decision and the provisions of the following standard(s) or other normative document(s) when installed in conformance with the installation instructions contained in the product documentation

### EMC

Emissions: EN61326-1:2013 Group 1 Class A

Immunity: EN61326-1:2013 Industrial Environment

### Clauses pertinent to the Machinery Directive of

EN61010-1:2010 Safety requirements for electrical equipment for measurement, control and laboratory use.

RoHs2: EN50581:2012 Technical documentation for the assessment of electrical and electronic products with respect to the restriction of hazardous substances.

Date of issue : 11/12/2017

Signed:

Name: Tony Power  
Position: Managing Director

A handwritten signature in black ink, appearing to read 'Tony Power', written over a horizontal line.

BS EN ISO9001:2008 approved  
Certificate number 860461

---

# Suppliers Declaration of Conformity Compliance Information Statement:

---

**IDENTIFICATION OF PRODUCT:**

ADR Touch Control PRO Console Models 37-4881/02, 36-2690/02, 36-2692/02 and 36-2694/02

**APPLICABLE COMPLIANCE STATEMENTS:**

EN 61326-1:2013 (CISPR 11) Group 1 Class A per PART 15 b)

per §15.19(a)(3)

This device complies with Part 15 of the FCC Rules. Operation is subject to the following two conditions:

(1) This device may not cause harmful interference, and

(2) this device must accept any interference received, including interference that may cause undesired operation

**TEST REPORT INFORMATION:**

dB Technology TR# R000372\_V00

**RESPONSIBLE PARTY (IN USA) NAME:** ELE International, Inc.

**ADDRESS:** PO Box 608, Loveland, CO 80539

**TELEPHONE:** 800-323-1242

**www.ELE.com**



# Noise Test Certificate

Issued By: **ELE International**

Date of Issue: 20 May 1999      ELE doc ref: 9901X0272

Date of Test: 20 May 1999



Page 1 of 1

Approved  
Signatory

<p><b>Product Description</b></p> <p>ELE ADR Touch Control PRO</p>	<p><b>Serial No.</b></p> <p>(See details on product identification plate)</p>																					
<div style="text-align: center;"> </div> <p><b>Notes:</b> Tests carried out with machine under load.</p>	<p><b>Measurements/recorded noise level</b></p> <table border="0"> <tr> <td>Position A</td> <td>72</td> <td>dB(A)</td> </tr> <tr> <td>Position B</td> <td>71</td> <td>dB(A)</td> </tr> <tr> <td>Position C</td> <td>72</td> <td>dB(A)</td> </tr> <tr> <td>Position D</td> <td>68</td> <td>dB(A)</td> </tr> <tr> <td>Position E</td> <td>70</td> <td>dB(A)</td> </tr> <tr> <td colspan="3">(Normal operator position)</td> </tr> <tr> <td>Background Noise level</td> <td>60</td> <td>dB(A)</td> </tr> </table>	Position A	72	dB(A)	Position B	71	dB(A)	Position C	72	dB(A)	Position D	68	dB(A)	Position E	70	dB(A)	(Normal operator position)			Background Noise level	60	dB(A)
Position A	72	dB(A)																				
Position B	71	dB(A)																				
Position C	72	dB(A)																				
Position D	68	dB(A)																				
Position E	70	dB(A)																				
(Normal operator position)																						
Background Noise level	60	dB(A)																				



ISO 9001:2008 approved  
Certificate number 0860461

Noise tests were carried out using Test Meter, serial No.

N30863

which has been calibrated using calibrated standards traceable to national standards of measurement.

**ELE International**  
Chartmoor Road, Chartwell  
Business Park, Leighton Buzzard,  
Beds, LU7 4WG England  
phone: + (0)1525 249200  
fax: + (0)1525 249249  
email: ele@eleint.co.uk  
http://www.ele.com  
ELE International, a division of  
Hach Lange Ltd



# PRODUCT SAFETY DATA SHEET

## COPY

SHELL TELLUS OIL T

Shell U.K. Oil, Shell-Mex House, Strand, London WC2R 0DX.  
Telephone 01-257-3000

Data Sheet No. LTEL02 Version : 16 11 89

BRANDNAMES :	SHELL TELLUS OIL T15	60406
	SHELL TELLUS OIL T37	60407
	SHELL TELLUS OIL T46	60408
	SHELL TELLUS OIL T100	60409

### PRODUCT INFORMATION

#### APPROVED USES

Shell Tellus Oil T are approved for use as :

hydraulic fluids and fluid power transmission oils.

If Shell Tellus Oil T are used for a purpose not covered in this section, Shell UK Oil would be grateful to receive information on the application.

#### KNOWN MISUSES/ABUSES

None known.

#### COMPOSITION

Shell Tellus Oil T are manufactured from highly refined mineral base oil derived from crude petroleum, and may contain additives, none of which give rise to any additional hazard in the finished product to that posed by the mineral oil components.

### PHYSICAL AND CHEMICAL PROPERTIES

Physical State :	Liquid at Ambient Temperatures
Appearance :	Pale/Dark Amber
Odour :	Characteristic Mineral Oil
IBP. :	> 280 Deg. C.
Vapour Density (Air = 1) :	> 5
Vapour Pressure @ 20 Deg. C. :	< 0.1 kPas
Sol. in Water :	Very Low
Acidity/Alkalinity :	Neutral

TYPICAL PROPERTIES	DENSITY @ 20 Deg C.	POUR POINT Deg C.	VISCOSITY in cSt. @ 40 Deg C. @ 20 Deg C.	
SHELL TELLUS OIL T15	0.87	-50	15	31
SHELL TELLUS OIL T37	0.87	-42	37	101
SHELL TELLUS OIL T46	0.88	-40	46	130
SHELL TELLUS OIL T100	0.89	-30	100	328

# COPY

## FIRE AND EXPLOSION HAZARDS

Flammability Limits - Upper : 10 % vol.  
 - Lower : 1 % vol.  
 Autoignition Temperature in Deg. C. : > 320  
 Extinguishants - Large Fire : Foam/Water Fog - NEVER USE WATER JET  
 - Small Fire : Foam/Dry Powder/CO2/Halon/Sand/Earth

FLASH POINT in Deg. C. by Pensky Marten Closed Cup unless stated otherwise.

SHELL TELLUS OIL T15	150
SHELL TELLUS OIL T37	177
SHELL TELLUS OIL T46	177
SHELL TELLUS OIL T100	153

See also section 4.2.2 'Fire and Explosion' in Part 1 (Page 9)

## SUPPLY CLASSIFICATION

Not Dangerous for Supply

See also section 4.2.6 'Product Handling' in Part 1 (Page 12)

## TRANSPORT CLASSIFICATION

Not Dangerous for Conveyance

See also section 4.2.4 'Product Receipt' in Part 1 (Page 10)

## STORAGE PRECAUTIONS

See also section 4.2.5 'Product Storage' in Part 1 (Page 11)

## ACUTE HEALTH HAZARDS AND ADVICE

Toxicity following single exposure to high levels (orally, dermally or by inhalation) is of a low order. The main hazards are: in the unlikely event of ingestion, aspiration into the lungs with possible resultant chemically induced pneumonia ; and, if the products are handled under high pressures, of high pressure injection injuries.

See also section 3.2 'Health Aspects of Petroleum Products' in Part 1 (Pages 4 - 7)

## INHALATION

Under normal conditions of use inhalation of vapours is not feasible or likely to present an acute hazard.

## SKIN

Skin contact presents no acute health hazard except in the case of high pressure injection injuries. These can lead to the loss of the affected limbs if not treated immediately and properly.

## PRECAUTIONS :

Avoid contact with the skin by the use of suitable protective clothing. Where skin contact is unavoidable, a high standard of personal hygiene must be practised. Extreme care must be exercised where the product is likely to be encountered at high pressures. Where high pressures are likely to be encountered, it is recommended that safe systems of work be employed.

## FIRST AID :

Skin contact does not normally require first aid, but oil soaked clothing should be removed, and contaminated skin washed with soap and water. If persistent irritation occurs, medical advice should be sought without delay.

Where a high pressure injection injury has occurred, medical attention should be obtained immediately. Show this Data Sheet and section 3.4 'Notes for Doctors' from Part I to the physician.



# PRODUCT SAFETY DATA SHEET

## COPY

### EYES

Eye contact may cause some discomfort.

#### PRECAUTIONS :

If there is a risk of splashing while handling the liquid, suitable eye protection should be used.

#### FIRST AID :

Flush the eye with copious quantities of water. If irritation persists refer for medical attention.

### INGESTION

The main hazard following ingestion is of aspiration into the lungs during subsequent vomiting.

#### PRECAUTIONS :

Accidental ingestion is unlikely. Normal handling and hygiene precautions should be taken to avoid ingestion.

#### FIRST AID :

DO NOT INDUCE VOMITING If ingestion is suspected, wash out the mouth with water, and send to hospital immediately. Show a copy of this data sheet and section 3.4 'Notes for Doctors' from Part I to the physician.

### CHRONIC HEALTH HAZARD AND ADVICE

Prolonged and repeated contact with oil products can be detrimental to health. The main hazards arise from skin contact and in the inhalation of mists. Skin contact under conditions of poor hygiene and over prolonged periods can lead to defatting of the skin, dermatitis, erythema, oil acne and oil folliculitis. Excessive and prolonged inhalation of oil mists may cause a chronic inflammatory reaction of the lungs and a form of pulmonary fibrosis.

Adherence to the precautions contained in section 3.3 'Health Precautions' in Part 1 (Pages 4 to 7) will minimise risks to health.

### EXPOSURE LIMIT VALUES

UK Maximum Exposure Limits :

UK Occupational Exposure Standards :

Oil Mist, Mineral :

5 mg/cubic metre 8-hour TWA value

10 mg/cubic metre 10-min TWA value

### RECOMMENDED PROTECTIVE CLOTHING

Impervious gloves and overalls where regular contact is likely, and goggles if there is a risk of splashing.

### COMBUSTION PRODUCTS

The substances arising from the thermal decomposition of these products will largely depend upon the conditions bringing about decomposition. The following substances may be expected :

Carbon Dioxide  
Carbon Monoxide  
Water  
Particulate Matter

Polycyclic Aromatic Hydrocarbons  
Unburnt Hydrocarbons  
Unidentified Organic and Inorganic Compounds

### DISPOSAL

See section 5.2.2 'Product Disposal' in Part 1 (Page 13)

**COPY**

**FURTHER INFORMATION**

The references set out below refer to the publications given in section 6 'Further Information' in Part 1 (Pages 14 & 15)

References : B1, B2.  
References : C4.  
References : E1  
References : L3, L6, L11, L15  
References : S12  
References : X2, X4, X10.  
References : Y1, Y3.  
References : Z3, Z8.

**EMERGENCY ACTION**

See section 7 'Emergency Action' in Part 1 (Page 16)

## DIRECTIVE ON WASTE ELECTRICAL & ELECTRONIC EQUIPMENT (WEEE)

	<p>Electrical equipment marked with this symbol may not be disposed of in European public disposal systems after 12 August of 2005. In conformity with European local and national regulations (EU Directive 2002/96/EC), European electrical equipment users must now return old or end-of life equipment to the Producer for disposal at no charge to the user.</p> <p><b>Note:</b> For return for recycling, please contact the equipment producer or supplier for instructions on how to return end-of-life equipment for proper disposal.</p> <p><b>Important document. Retain with product records.</b></p>
<p><b>GERMAN</b></p> <p>Elektrogeräte, die mit diesem Symbol gekennzeichnet sind, dürfen in Europa nach dem 12. August 2005 nicht mehr über die öffentliche Abfallentsorgung entsorgt werden. In Übereinstimmung mit lokalen und nationalen europäischen Bestimmungen (EU-Richtlinie 2002/96/EC), müssen Benutzer von Elektrogeräten in Europa ab diesem Zeitpunkt alte bzw. zu verschrottende Geräte zur Entsorgung kostenfrei an den Hersteller zurückgeben.</p> <p><b>Hinweis:</b> Bitte wenden Sie sich an den Hersteller bzw. an den Händler, von dem Sie das Gerät bezogen haben, um Informationen zur Rückgabe des Altgeräts zur ordnungsgemäßen Entsorgung zu erhalten.</p> <p><b>Wichtige Informationen. Bitte zusammen mit den Produktinformationen aufbewahren.</b></p>	
<p><b>FRENCH</b></p> <p>A partir du 12 août 2005, il est interdit de mettre au rebut le matériel électrique marqué de ce symbole par les voies habituelles de déchetterie publique. Conformément à la réglementation européenne (directive UE 2002/96/EC), les utilisateurs de matériel électrique en Europe doivent désormais retourner le matériel usé ou périmé au fabricant pour élimination, sans frais pour l'utilisateur.</p> <p><b>Remarque :</b> Veuillez vous adresser au fabricant ou au fournisseur du matériel pour les instructions de retour du matériel usé ou périmé aux fins d'élimination conforme.</p> <p><b>Ce document est important. Conservez-le dans le dossier du produit.</b></p>	
<p><b>ITALIAN</b></p> <p>Le apparecchiature elettriche con apposto questo simbolo non possono essere smaltite nelle discariche pubbliche europee successivamente al 12 agosto 2005. In conformità alle normative europee locali e nazionali (Direttiva UE 2002/96/EC), gli utilizzatori europei di apparecchiature elettriche devono restituire al produttore le apparecchiature vecchie o a fine vita per lo smaltimento senza alcun costo a carico dell'utilizzatore.</p> <p><b>Nota:</b> Per conoscere le modalità di restituzione delle apparecchiature a fine vita da riciclare, contattare il produttore o il fornitore dell'apparecchiatura per un corretto smaltimento.</p> <p><b>Documento importante. Conservare con la documentazione del prodotto.</b></p>	
<p><b>DANISH</b></p> <p>Elektriske apparater, der er mærket med dette symbol, må ikke bortskaffes i europæiske offentlige affaldssystemer efter den 12. august 2005. I henhold til europæiske lokale og nationale regler (EU-direktiv 2002/96/EF) skal europæiske brugere af elektriske apparater nu returnere gamle eller udtjente apparater til producenten med henblik på bortskaffelse uden omkostninger for brugeren.</p> <p><b>Bemærk:</b> I forbindelse med returnering til genbrug skal du kontakte producenten eller leverandøren af apparatet for at få instruktioner om, hvordan udtjente apparater bortskaffes korrekt.</p> <p><b>Vigtigt dokument. Opbevares sammen med produktdokumenterne.</b></p>	

### SWEDISH

Elektronikutrustning som är märkt med denna symbol kanske inte kan lämnas in på europeiska offentliga sopstationer efter 2005-08-12. Enligt europeiska lokala och nationella föreskrifter (EU-direktiv 2002/96/EC) måste användare av elektronikutrustning i Europa nu återlämna gammal eller uttrangerad utrustning till tillverkaren för kassering utan kostnad för användaren.

**Obs!** Om du ska återlämna utrustning för återvinning ska du kontakta tillverkaren av utrustningen eller återförsäljaren för att få anvisningar om hur du återlämnar kasserad utrustning för att den ska bortskaffas på rätt sätt.

**Viktigt dokument. Spara tillsammans med dina produktbeskrivningar.**

### SPANISH

A partir del 12 de agosto de 2005, los equipos eléctricos que lleven este símbolo no deberán ser desechados en los puntos limpios europeos. De conformidad con las normativas europeas locales y nacionales (Directiva de la UE 2002/96/EC), a partir de esa fecha, los usuarios europeos de equipos eléctricos deberán devolver los equipos usados u obsoletos al fabricante de los mismos para su reciclado, sin coste alguno para el usuario.

**Nota:** *Sírvase ponerse en contacto con el fabricante o proveedor de los equipos para solicitar instrucciones sobre cómo devolver los equipos obsoletos para su correcto reciclado.*

**Documento importante. Guardar junto con los registros de los equipos.**

### DUTCH

Elektrische apparatuur die is voorzien van dit symbool mag na 12 augustus 2005 niet meer worden afgevoerd naar Europese openbare afvalsystemen. Conform Europese lokale en nationale wetgeving (EU-richtlijn 2002/96/EC) dienen gebruikers van elektrische apparaten voortaan hun oude of afgedankte apparatuur kosteloos voor recycling of vernietiging naar de producent terug te brengen.

**Nota:** *Als u apparatuur voor recycling terugbrengt, moet u contact opnemen met de producent of leverancier voor instructies voor het terugbrengen van de afgedankte apparatuur voor een juiste verwerking.*

**Belangrijk document. Bewaar het bij de productpapieren.**

### POLISH

Sprzęt elektryczny oznaczony takim symbolem nie może być likwidowany w europejskich systemach utylizacji po dniu 12 sierpnia 2005. Zgodnie z europejskimi, lokalnymi i państwowymi przepisami prawa (Dyrektywa Unii Europejskiej 2002/96/EC), użytkownicy sprzętu elektrycznego w Europie muszą obecnie przekazywać Producentowi stary sprzęt lub sprzęt po okresie użytkowania do bezpłatnej utylizacji.

**Uwaga:** *Aby przekazać sprzęt do recyklingu, należy zwrócić się do producenta lub dostawcy sprzętu w celu uzyskania instrukcji dotyczących procedur przekazywania do utylizacji sprzętu po okresie użytkowania.*

**Ważny dokument. Zachować z dokumentacją produktu.**

### PORTUGUESE

Qualquer equipamento eléctrico que ostente este símbolo não poderá ser eliminado através dos sistemas públicos europeus de tratamento de resíduos sólidos a partir de 12 de Agosto de 2005. De acordo com as normas locais e europeias (Directiva Europeia 2002/96/EC), os utilizadores europeus de equipamentos eléctricos deverão agora devolver os seus equipamentos velhos ou em fim de vida ao produtor para o respectivo tratamento sem quaisquer custos para o utilizador.

**Nota:** *No que toca à devolução para reciclagem, por favor, contacte o produtor ou fornecedor do equipamento para instruções de devolução de equipamento em fim de vida para a sua correcta eliminação.*

**Documento importante. Mantenha junto dos registos do produto.**