

# OPERATING INSTRUCTIONS

## Humidifier 500 cubic metre and Water Level Device

**39-1510/01**

<p><b>ELE International</b> Chartmoor Road, Chartwell Business Park Leighton Buzzard, Bedfordshire, LU7 4WG England phone: +44 (0) 1525 249200 fax: +44 (0) 1525 249249 email: <a href="mailto:ele@eleint.co.uk">ele@eleint.co.uk</a> <a href="http://www.ele.com">http://www.ele.com</a> ELE International, a division of Hach Lange Ltd.</p>	<p><b>Distributor:</b></p>	<p><b>ELE International</b> Soiltest Product Division PO Box 389, Loveland, CO 80539 USA phone: +1 (800) 323 1242 fax: +1 (970) 663 9781 email: <a href="mailto:soiltest@eleusa.com">soiltest@eleusa.com</a> <a href="http://www.eleusa.com">http://www.eleusa.com</a></p>
<p><i>In the interests of improving and updating its equipment, ELE reserves the right to alter specifications to equipment at any time.</i> <b>ELE International 2016 ©</b></p>		

---

**Contents**

<b>Section</b>	<b>Page</b>
<b>1 Check on Delivery</b>	<b>3</b>
<b>2 Design and Principle of Operation</b>	<b>3</b>
<b>3 Permissible Operating Conditions</b>	<b>3</b>
<b>4 Positioning</b>	<b>4</b>
<b>5 Adjustment of Mist Fineness</b>	<b>4</b>
<b>6 Control</b>	<b>4</b>
<b>7 Maintenance</b>	<b>4</b>
<b>8 Cleaning</b>	<b>4</b>
<b>9 Breakdowns</b>	<b>5</b>
<b>10 Accessories</b>	<b>5</b>
<b>11 Technical Data</b>	<b>7</b>
<b>12 Spare Parts</b>	<b>8</b>

---

**This manual should be read and understood in its entirety prior to operation of the machine.**

## **1 Check on Delivery**

Please check the consignment for damage caused during transit. Any damage found should be immediately reported to the carriers who handled the equipment and ELE International.

## **2 Design and Principle of Operation**

The Humidifier consists of the following main components:

Water reservoir.

Motor with impeller fitted to the motor shaft and suction pipe.

The Humidifier uses the atomizing method. The water is pumped upwards by rotation through the suction pipe onto the impeller disks and is thrown against an atomizing ring. The air required for atomization is drawn in by the fan, which also distributes the mist in the room.

## **3 Permissible Operating Conditions**

### **3.1 Mains voltage:**

Any mains voltage fluctuations should be within 10% of the voltage specified on the rating plate.

### **3.2 Room temperatures:**

Faultless functioning of the equipment can only be guaranteed at room temperatures from 2°C to 35°C.

### **3.3 Continuous operation:**

Although the unit will not be damaged by continuous operation, it must be used within the specified parameters (see section 11), so that the required humidity is reached within a short time and the equipment is periodically switched off. In practice, the total operating period per day should not exceed 12 - 16 hours.

### **3.4 Hard water**

In the case of extremely high lime content in the water, we recommend the installation of a demineralizer to protect the unit from lime deposits and to prevent the possible distribution of lime dust in the room. Phosphate cartridges in the water feed pipe are not suitable for our equipment and the same applies to base exchangers (softening agents).

### **3.5 Air with a high dust content**

In the case of air with a high dust content, particularly fibrous dust (air-borne), a dust filter must be used.

### **3.6 Additions of active substances**

We cannot bear responsibility for any damage caused through the use of additives or active substances not recommended by us, including damage to our equipment caused by aggressive chemicals precipitated from the room air.

## **4 Positioning**

Whenever possible, the units should be positioned within a free space of 2-4m diameter and not less than 2m below the ceiling. When the deflector hood is used, the unit can also be installed against a wall. In this case the minimum distance between the top edge of the Humidifier and the ceiling is 1.2m.

In case of shed-type buildings, attention should be paid to the following. Since humid air is lighter than dry air and therefore rises, the units should not be installed under the roof, otherwise condensation may occur on the skylights or the humidity may escape through open air vents.

Any cold water pipes within the throw of the mist should be insulated.

## **5 Adjustment of Mist Fineness**

5.1 Standard mist: Operation without collar. Output at 60% relative humidity and 20°C. 2.4 litre/hr.

5.2 Fine mist: Use collar. Output at 60% relative humidity and 20°C. 2.4 litre/hr.

Liquids with lower surface tension and rate of evaporation than water produce larger atomized particles, which may under certain circumstances lead to considerable condensation in the vicinity of the unit. Liquids of this kind should therefore not be used, or a sleeve should be fitted. Only clean water should be used for air humidification.

## **6 Control**

Automatic water feed is achieved by means of the float chamber with level monitor. The float chamber can be used wherever a water overflow is either available or easy to install. The connected pressure is 0.3 – 6.0 Bar.

## **7 Maintenance**

The Humidifier is equipped with a maintenance free motor which does not require re-lubrication. Apart from regular cleaning, the appliance requires no maintenance.

## **8 Cleaning**

### **8.1 Ordinary cleaning**

In the case of continuous operation this should be carried out weekly. In the case of infrequent operation it only needs to be carried out after use.

Remove the impeller, cover the top opening by means of a piece of cardboard or similar and run the appliance with 1-2 litres of lukewarm water max. 40°C and a little washing up liquid for 2 - 3 minutes, then rinse with fresh water. Remove the filter from the suction pipe and clean separately. Rinse the water reservoir thoroughly with water.

### **8.2 Thorough cleaning**

If the output of the unit drops because of the accumulation of dirt, a more thorough cleaning cycle has to be undertaken. Take off the suction pipe, taking care to loosen only the screws visible from the outside. The covered screws must under no circumstances be slackened off since this would throw the impeller out of balance.

Clean exit parts to the impeller disks (possibly with a bent strip of sheet metal), and remove residue in the atomizing ring with a hard paint brush.

Rotate impeller by hand and check that it does not chafe against the atomizing ring. Flush the unit carefully with mains water.

After cleaning, allow the unit to drip off for at least quarter of an hour in its normal position. Subsequently run the unit for quarter of an hour without water.

### 8.3 Periodical thorough cleaning

Every 6 – 12 months put the unit upside down and detach the top part of the housing by loosening the three screws in the feet of the unit. Next, only slacken the 14mm hexagon head screws in the 'u' notches and remove the other two screws. Lift out the atomizer assembly. **DO NOT** open the motor cover! Clean the atomizing ring and the inside of the unit, then proceed as per 'Thorough cleaning' (section 8.2).

## 9 Breakdowns

If loud noises are produced by the bearings (rolling, whistling, humming), the unit must be switched off immediately and sent to ELE International for replacement of the bearings.

## 10 Accessories

During atomization, the Humidifier unit acts as a very efficient air washer. Granular dust sinks down in the water basin and can easily be removed. The fibrous dust found in paper and textile mills may, however, obstruct the water and air intake of the appliance, thus considerably reducing its output. Large amounts of dust may even clog the unit completely.

We have made the greatest efforts to find an appropriate dust filter for the Humidifier and we have found the best solution: the round filter brush retains the fibrous dust particles without affecting the air inlet and the performance of the unit. This filter brush requires only a moderate initial investment without consecutive maintenance costs as it contains no parts subject to wear.

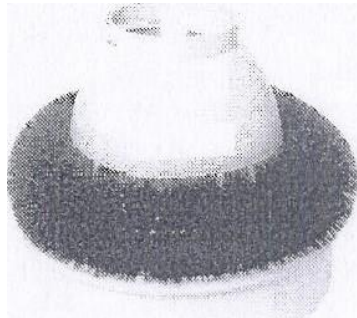

This filter brush is fixed to an aluminium ring, which can put the appliance into the water reservoir (see figure above). The electric flex of the appliance must be drawn through the ring. The air required by the unit is then forced to pass through the filter brush, which traps the fibrous dust. This prevents the accumulation of dirt in the unit to a large extent, and maintenance can be carried out at longer intervals.

Cleaning the filter brush:

Depending on the dust load of the air, the filter brush requires cleaning on a regular basis. The cleaning procedure is simple: remove the aluminium ring with the brush, then clean the filter, either:

- using a vacuum cleaner, or
- using compressed air (not in the same room), or
- using fresh water (from tap or water hose).

**Wait until the dust filter is completely dry before reinstalling it**, otherwise the bristles may get out of shape, thus reducing the performance of the filter.

If you are using a water container larger than the 6 litre control basin, cover the container with a sheet-metal plate or a piece of cardboard, then cut out a round hole corresponding to the diameter of the 6 litre basin. This recess holds the unit and the dust filter.

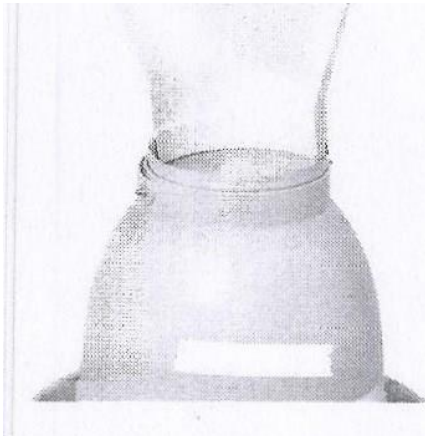

The deflector hood, which is made of plexiglas, enables the mist emerging from the unit to be deflected at an angle of inclination of approximately 30°. For this purpose, the deflector hood is mounted on the opening unit and the latter is then used without the standard insertion collar. If the output is too high, the deflector hood can also be mounted on the insertion collar, but the propeller may then brush the hood slightly owing to the reduction in diameter. In this case the propeller should be shortened a little each end with the aid of a sharp pair of scissors. To avoid spurts, make sure that the propeller is right on top of the shaft end and rotates in the bottom portion of the hood.

Use of the deflector hood is recommended when the Humidifier unit is mounted on a wall or a pillar so as to prevent the wall behind the unit being made wet by the mist. A further application for the deflector hood is in cases where the mist has to be diffused in a certain direction. Use of the deflector hood will reduce the output of the unit by approximately 10-20%.

### **Control basin 2**

For continuous water supply the control basin is provided with a sediment drain screw so that it can be cleaned without being dismantled. The control basin can be used wherever a water drain is available or can be easily installed.

---

## 11 Technical Data

Humidification capacity	Up to 3 litres/hr
For rooms	Up to 500m <sup>3</sup>
Air circulation	280m <sup>3</sup> /hr
Power consumption	65 watt
Dimensions (diameter x height)	420 x 350 mm
Dry weight	7 kg
Voltages	110/230/240v 50Hz 110/230v 60Hz

12 Spare Parts

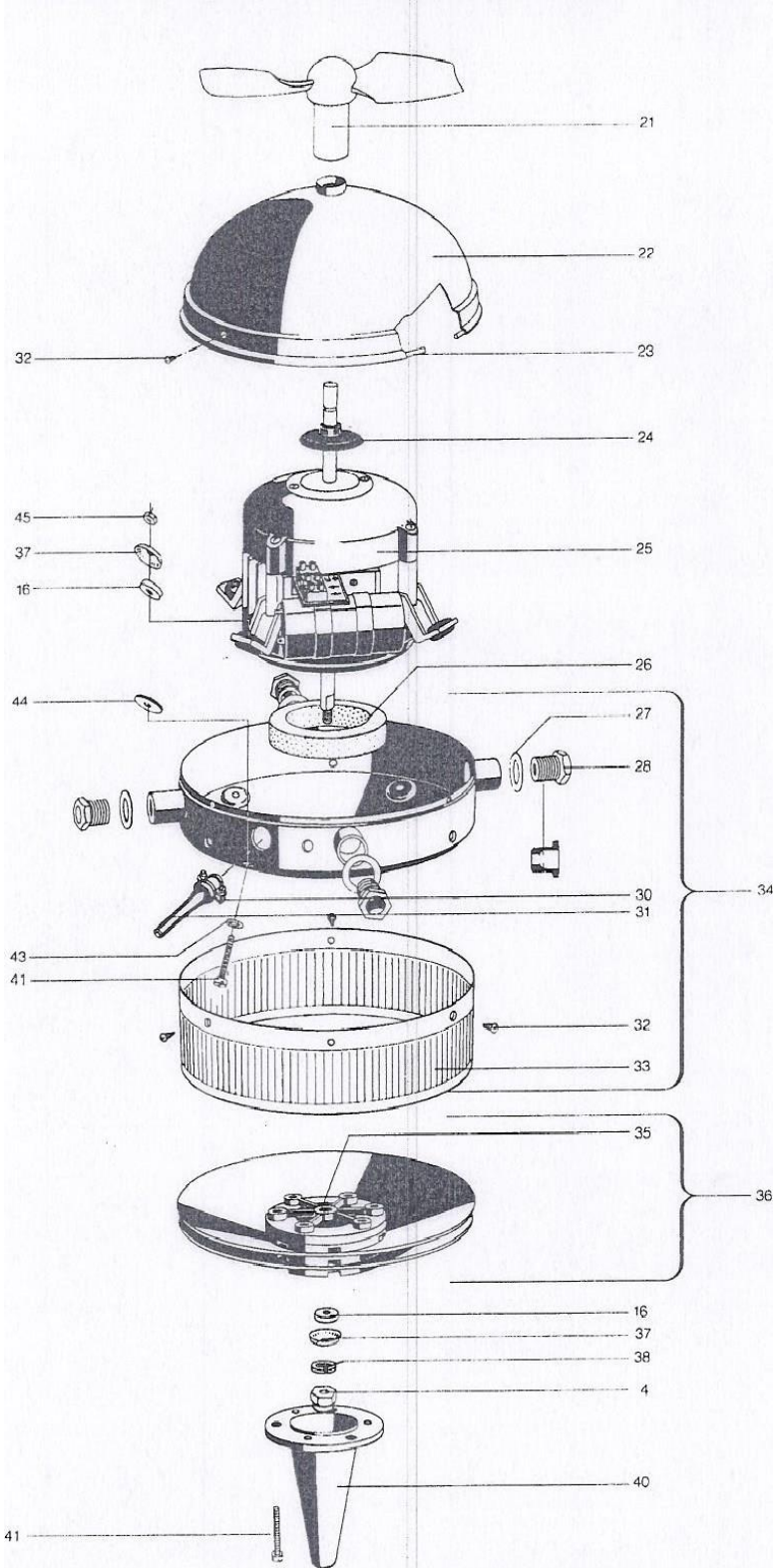





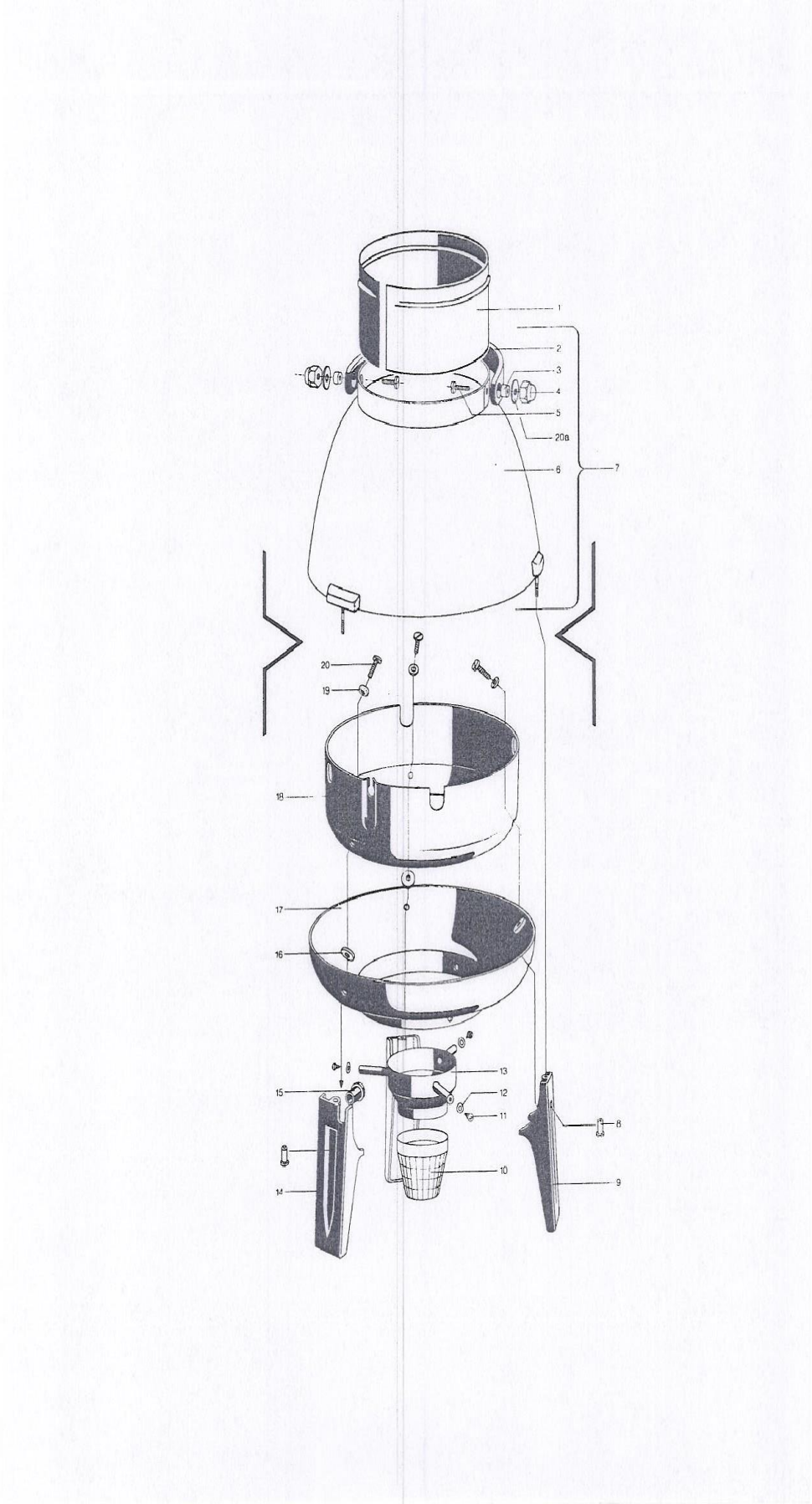

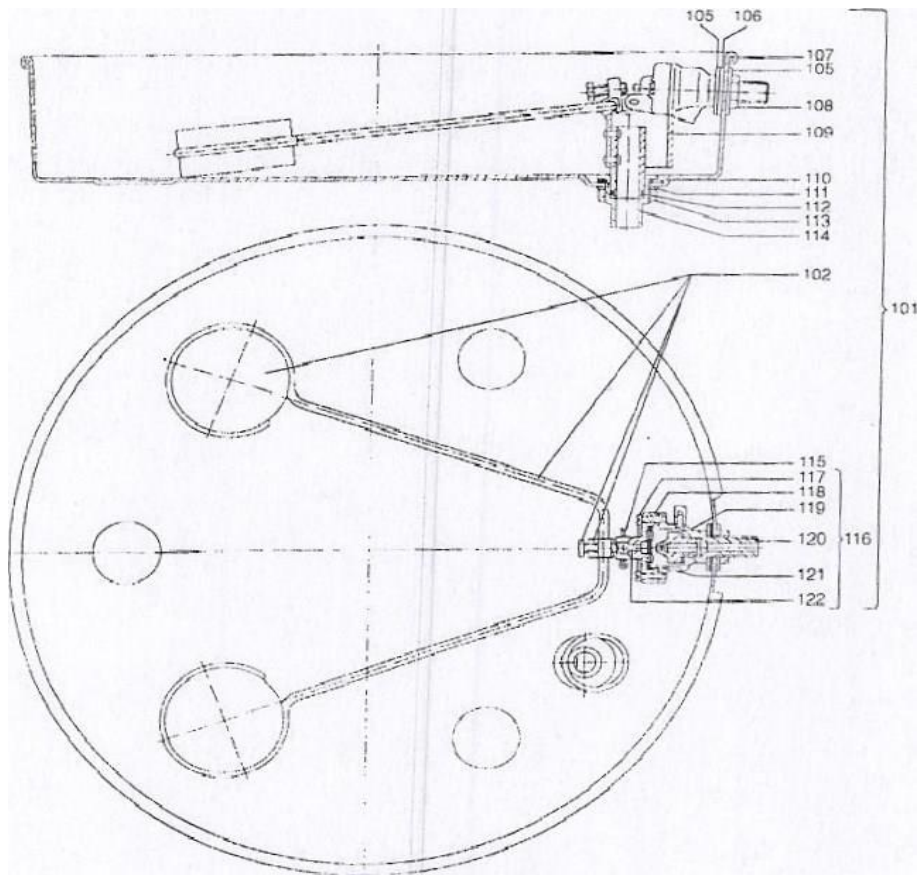

101	Control basin 2
102	Float supporting frame kpl
105	Washer
106	Washer
107	Basin
108	Nut
109	Overflow stand pipe cpl.
110	Joint
111	Washer
112	O-ring
113	Nut
114	Drain pipe
115	Split pin
116	Nozzle holder cpl.
117	Cylinder head screw
118	Cover
119	Washer
120	Nozzle
121	Diaphragm
122	Valve pin