

# OPERATING INSTRUCTIONS

## Digital Tritest 50

### 25-3518/01

(Serial Numbers: 1936-1-XXXX)

<b>ELE International</b> Chartmoor Road, Chartwell Business Park Leighton Buzzard, Bedfordshire, LU7 4WG England phone: +44 (0) 1525 249200 fax: +44 (0) 1525 249249 email: <a href="mailto:ele@eleint.co.uk">ele@eleint.co.uk</a> <a href="http://www.ele.com">http://www.ele.com</a> ELE International, a division of Hach Lange Ltd.	<b>Distributor:</b>	<b>ELE International</b> Soiltest Product Division PO Box 389, 5600 Lindbergh Drive Loveland, CO 80539 USA phone: +1 (970) 663 9780 fax: +1 (970) 663 9781 email: <a href="mailto:soiltest@eleusa.com">soiltest@eleusa.com</a> <a href="http://www.eleusa.com">http://www.eleusa.com</a>
<p><i>In the interests of improving and updating its equipment, ELE reserves the right to alter specifications to equipment at any time.</i></p> <p><b>ELE International 2019 ©</b></p>		

## Contents

<b>Section</b>	<b>Page</b>
1 Safety.....	5
2 Introduction.....	6
3 Specifications.....	7
4 Installation.....	8
4.1 Mechanical.....	8
4.2 Electrical- Power Supply.....	8
5 Portable Appliance Tests.....	9
6 Controls/Description.....	9
6.1 Mains On/Off.....	9
6.2 Mode Selection.....	10
6.3 Manual Mode.....	10
6.4 Pause-Mode.....	11
6.5 Serial Mode.....	11
6.6 Additional Serial Commands (Metric).....	13
6.7 Alternative Serial Commands (Imperial).....	14
6.8 Return-To-Datum.....	14
6.9 Set-Up Mode.....	14
6.10 Set-Up Serial Interface.....	15
6.11 E-Stop and Safety/ID.....	15
7 Operation.....	15
8 Maintenance.....	16
9 Accessories.....	16
10 Certifications.....	16
11 Appendix A: RS232.....	17

EC Declaration of Conformity

WEEE Directive

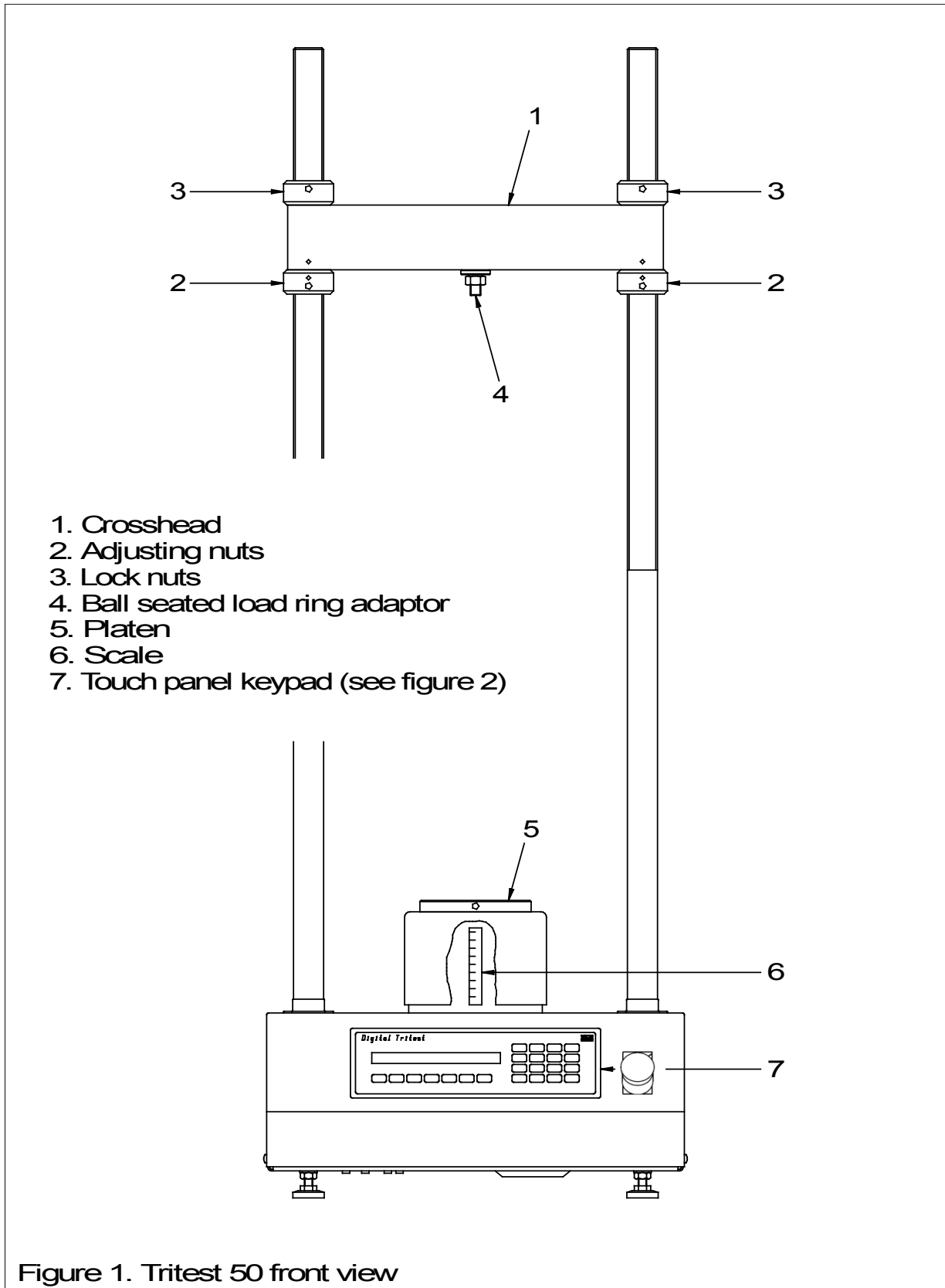

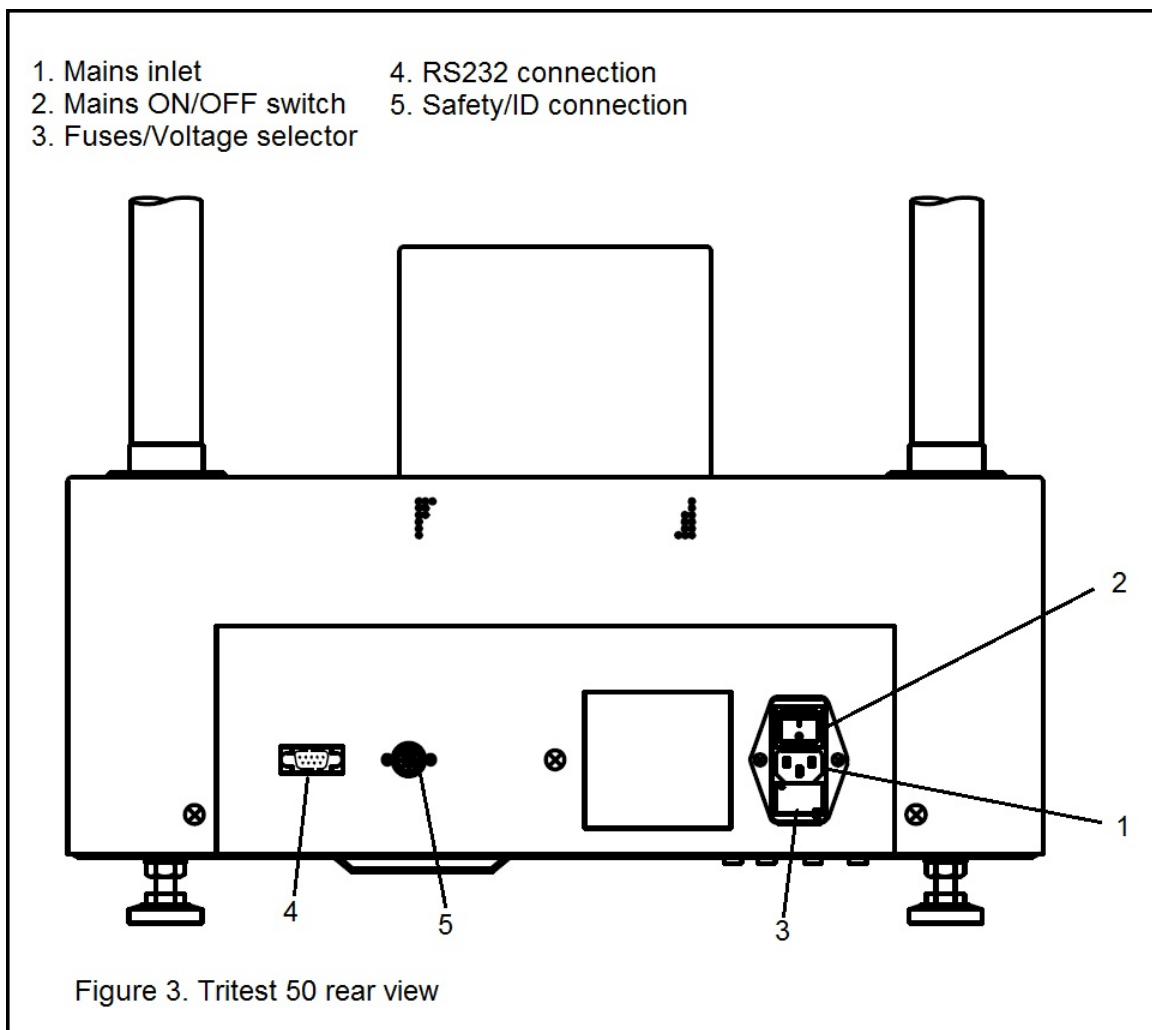
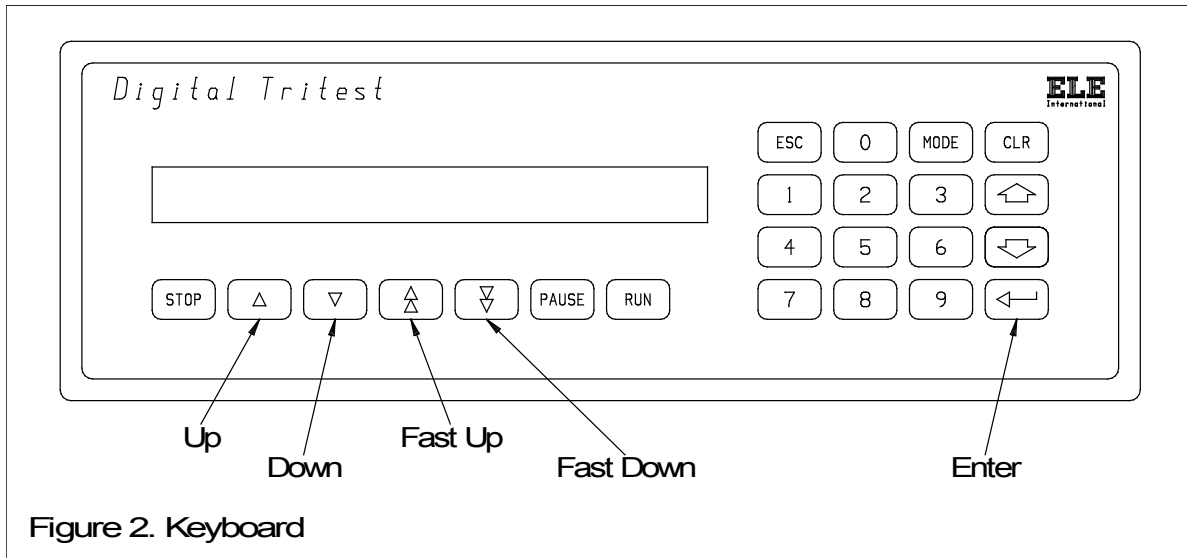

## 1 Safety

This equipment has been tested by ELE International and is safe to use providing that the proper safety precautions are observed:

***Do not use this equipment in any manner, other than as specified in this user manual; misuse may result in serious injury to personnel.***

***Do not attempt to operate the equipment with covers removed.***

***Only connect to the correct electrical supply. Equipment voltage setting is stated on the fuse cover of the appliance inlet module.***





***Refer to Installation section before installing machine.***

***Do not operate machine with wet hands.***

Please read this entire manual before unpacking, setting up, or operating this equipment. Pay particular attention to all **DANGER** and **CAUTION** statements. Failure to do so could result in serious injury to the operator, or other personnel, or damage to the equipment.

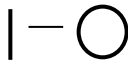
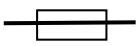
Ensure all moving parts are thoroughly secured before attempting any maintenance.

### 1.1 Symbols

	<b>PROTECTIVE CONDUCTOR TERMINAL</b> Equipment safety earthing point
	<b>“ I ” = SUPPLY SWITCHED “ON”</b> <b>“ O ” = SUPPLY SWITCHED “OFF”</b>
	<b>FUSE, FOR SAFE OPERATION OF THE EQUIPMENT, USE ONLY FUSES WITH RATINGS SPECIFIED</b>
	<b>Earth (ground) TERMINAL</b> Not for safety earthing purposes but provide an earth reference point.
	<b>Caution, risk of electric shock</b>
	<b>Caution - refer to accompanying documents</b>
	<b>Equipment conforms to the requirements of European CE Directives, as stated on the Declaration of Conformity</b>

General Information: In no event will the manufacturer be liable for direct, indirect, special, incidental or consequential damages resulting from any defect or omission in this manual. The manufacturer reserves the right to make changes in this manual and the products it describes at any time, without notice, or obligation. Revised editions are found on the manufacturer's website.

Important Note: The manufacturer is not responsible for any damages due to misapplication or misuse of this product including, without limitation, direct, incidental and consequential damages, and disclaims such damages to the full extent permitted under applicable law. The user is solely responsible to identify critical application risks and install appropriate mechanisms to protect processes during a possible equipment malfunction.

## 1.2 Use of Hazard Information

### **DANGER**

Indicates a potentially or imminently hazardous situation which, if not avoided, will result in death or serious injury.

### **WARNING**

Indicates a potentially or imminently hazardous situation which, if not avoided, could result in death or serious injury.

### **CAUTION**

Indicates a potentially hazardous situation that may result in minor or moderate injury.

**Important Note:** Information that requires special emphasis.

**Note:** Information that supplements points in the main text.

## 2 Introduction

These instructions are for machines with a serial number beginning with 1936 issue 1, i.e. of the format 1936-1-XXXX and onwards..

The Digital Tritest 50 is specifically designed for the triaxial testing of soil specimens and will also perform compression tests on a wide range of materials up to the maximum load of 50 kN.

Careful consideration has been given to the stability of the twin column construction.

The forces applied are generated by a ballscrew jack driven by an electric motor via a spur gearbox.

The gearbox is grease packed and lubricated for life and requires no maintenance.

Control of the machine is by a touch panel keypad with information being displayed on a backlit LCD display (figure 2).

Ram travel safety limit switches are fitted internally and protect the mechanism on both upward and downward movements of the ram.

A scale (6) (figure 1), situated underneath the platen shroud, becomes visible when the platen is raised from its lowest position and provides an approximate indication of platen travel.

An RS232 outlet (4) (figure 3) is a standard feature of these machines and is situated at the rear (see appendix A for details).

A Safety/ID connector (5) (figure 3) is a new feature of these machines and is situated at the rear. This connection is optional when interfacing with other ELE equipment.

The crosshead (1) (figure 1) position is easily adjusted and accepts a wide range of test apparatus.

A ball seated load ring adaptor (4) (figure 1) is provided which accepts load rings up to, and including, 50 kN.

An E-Stop button on the front of the unit performs a STOP function (figure 1).

NOTE : The unit will automatically restart when this is released.

### 3 Specifications

Capacity	50 kN
Approximate dimensions	490 x 500 x 1420 mm (length x width x height) (19.3 x 19.7 x 55.9 inches)
Enclosure	Metal casing with painted finish, for indoor use only.
Temperature	5° C to 40° C, (41° F to 104° F)
Relative Humidity	Up to 80% for temperatures up to 31° C, decreasing linearly to 50% RH at 40° C
Operating Altitude	2000m maximum
Pollution category	2
Installation category	II
Protection Class	Class 1 (Protective earth ground connected)
Maximum vertical clearance	910 mm (platen down crosshead up)
Minimum vertical clearance	305 mm (platen up crosshead down)
Horizontal clearance	364 mm
Platen travel	100 mm
Weight (approximate)	90 kg, (198 lbs)
Speed range metric Fwd/Rev/Run	0.00001 – 9.99999 mm/min
Speed range imperial Fwd/Rev/Run	0.000001 – 0.399999 in/min
Serial interface	RS232 (Standard) Programmable baud rate and protocol.
Supply voltage(s)	115/230 Vac, 50/60 Hz, single phase
Power consumption	0.3 / 0.15A
Certifications	CE Marked and ETL listed to UL and CSA standards

## 4 Installation

**WARNING – Personal Injury Hazards.** Only qualified personnel should conduct the installation tasks described in this section of the manual.

### 4.1 Mechanical

**DANGER: The Tritest 50 is very heavy; it weighs more than 90 kg (198 lbs.). Do not attempt to unpack, carry or move without proper equipment and sufficient people to do so safely. Remember, always lift with your legs, not with your back. If you have a history of back problems or cardiovascular problems, do not attempt to unpack or lift the Tritest 50.**

The machine should be installed on a level bench capable of supporting Tritest 50's gross weight, and with sufficient space for safe operation of the equipment. The machine is provided with adjustable feet to compensate for any out of level, or unevenness, of the bench surface.

To position the crosshead (1) (Figure 1), loosen the two adjusting nuts (2) (figure 1) and the two lock nuts (3) (figure 1) the required amount. To ensure that the crosshead is level, the dots on the adjusting nuts should coincide with corresponding dots on the crosshead. Check by means of a spirit level or by direct measurement. Tighten the lock nuts using the Tommy Bar supplied.

Make sure that the back of the machine is not less than 50 mm from any wall or similar object. The louvres in the underside of the machine and the grill in the rear must be kept clear of obstructions.

This equipment is suitable for non-hazardous locations.

### 4.2 Electrical- Power Supply

**DANGER: Servicing of this equipment must be performed by a qualified ELE service technician. Before removing any covers or performing maintenance repair and service, isolate from electrical supply by removing mains plug. Where mains supply connection is required during these activities, only fully trained technicians should perform the work.**

**DANGER: This unit is dual pole fused having both line and neutral fused, hence the two fuses for both 115V and 230V operation.**

**DANGER: Misapplication of the voltage to the machine can result in both electrical hazards and damage to the equipment. The position of the fuseholder drawer in the power inlet module determines the line voltage the machine is set for. The machine normally ships factory set for the correct voltage for the supplied power cord, but ALWAYS verify proper line voltage settings prior to applying power during the initial installation/s. (See item 2 in the following paragraph for details.)**

Fuses/Voltage Selector (3) (See Figure 3, Item 3)



If it is necessary to convert the product to a different line voltage, the line voltage must be manually switched and a suitable line cord for the voltage must be connected before connecting to mains power. The machine's voltage setting can be changed by removing and repositioning the fuseholder drawer, located in the machines power inlet module. To change the machines line voltage:

- 1) Pull the fuseholder drawer from the power inlet module. (When changing voltage it is not necessary to replace the fuses. The supplied T 1.6A, 250V fuses are suitable for either 115 or 230 volt, 50/60 Hz, 26W operation.)
- 2) Select the desired line voltage by aligning the voltage setting on the fuseholder drawer. The desired voltage setting (i.e. 110-120V or 220-240V) must be upright at the base of the fuseholder drawer; the selected voltage indicator's arrow will be pointing down. When properly oriented, push the fuseholder drawer into the power inlet module for the desired line voltage.
- 3) Select and install a power cord suitable for the local country code. (A 3 conductor power cord with Protective Earth (Ground) terminal is required.)

***DANGER: A good low impedance Protective Earth Ground connection is required to the power cord to assure electrical safety.***

## 5 Portable Appliance Tests

All ELE designed products are tested for electrical safety prior to sale.

An electrical safety test label is fitted, (usually adjacent to the mains input socket).

Users of this equipment have an obligation to ensure equipment is maintained and is safe for use.

***IMPORTANT NOTE: DO NOT FLASH TEST ELECTRONIC EQUIPMENT.***

If in doubt as to the most suitable connection point (which will usually be an earth stud or an external earth connection) contact ELE Service Department for assistance.

## 6 Controls/Description

### 6.1 Mains On/Off

The main switch is situated at the rear of the machine, this switch turns the power supply ON and OFF.

When the mains supply is first switched on the display will show:

TRITEST-50	V* . **
<< SYSTEM CHECK >>	

This will remain for approximately 2 seconds, during which time a series of automatic, electronic checks are made. If the checks are passed, the display will show either:

The top line shows the firmware release version number, eg. 'V4.01'.

(MANUAL) = STOP =	x.xxxxx mm/min
[Mode] / Enter Speed	#.##### mm/min

or...

(MANUAL)	= STOP =	0.xxxxxx in/min
[Mode] / Enter	Speed	0.##### in/min

or...

(RS232)	= STOP =	0.00000 mm/min
[	]RX TX[	]

or...

(RS232)	= STOP =	0.000000 in/min
[	]RX TX[	]

**Note:** x.xxxxx denotes last speed retained in memory.

## 6.2 Mode Selection

The [Mode] key is used to enable the selection of the system's various operating modes. These are:

<b>Manual</b>	Control from front panel push buttons and keypad
<b>Serial</b>	Control via serial RS232 interface
<b>Set 0 Datum</b>	Set Datum position for Return-to-Datum function
<b>Set-Up</b>	Configuration for Serial Interface protocol and System Options (units/type/contrast/diagnostics)

When the [Mode] key is repeatedly pressed, the bottom line display will scroll through:

```
' [Enter] [Mode] : Manual           or [Esc] '
' [Enter] [Mode] : Serial           or [Esc] '
' [Enter] [Mode] : Set 0 Datum      or [Esc] '
' [Enter] [Mode] : Set-Up          or [Esc] '
```

When the desired mode is displayed, press the [Enter] key to select it, or press the [Esc] key to abort and return to the current mode.

## 6.3 Manual Mode

The display will show:

(MANUAL)	= STOP =	x.xxxxx mm/min
[Mode] / Enter	Speed	#.##### mm/min

The top line shows the system status and the preset speed.

The preset speed may be changed, at any time, by numeric entry via the keypad. The new speed will be indicated on the bottom line, in place of the # markers, and will become active when the Enter [Ent] key is pressed. The Clear [Clr] key may be used to clear an erroneous entry prior to the [Ent] key being pressed. Trailing zeros do not need to be entered.

The motor is controlled by the Command Push Buttons:

[Stop]	Cancels all movement functions	<i>motor stops</i>
--------	--------------------------------	--------------------

[Up]	Move UP at Preset Speed	<i>momentary</i>
[Down]	Move DOWN at Preset Speed	<i>latching</i>
[Fast Up]	Move UP at Fast Speed	<i>momentary</i>
[Fast Down]	Move DOWN at Fast Speed	<i>latching</i>
[Pause]	See Pause-Mode later	<i>latching</i>
[Run]	Move UP at Preset Speed	<i>latching</i>
[↕]	Return-to-Datum (if Datum 0 Set)	<i>latching</i>

The system's status is indicated on the display as follows:

=STOP=	<i>steady</i>	Motor stopped normally
↑ RUN ↑	<i>flashing</i>	Run Mode, moving UP Preset Speed
↑	<i>flashing</i>	Moving UP at Preset Speed
↓	<i>flashing</i>	Moving DOWN at Preset Speed
↑↑	<i>flashing</i>	Moving UP at Fast Speed
↓↓	<i>flashing</i>	Moving DOWN at Fast Speed
PAUSE	<i>steady</i>	Paused (stopped) in Run Mode
↓STOP↓	<i>flashing</i>	Stopped at Overtravel limit
↑STOP↑	<i>flashing</i>	Stopped at Undertravel limit
↕ ↓↓	<i>flashing</i>	Returning to Datum
↕ ↑↑	<i>flashing</i>	Returning to Datum

#### 6.4 Pause-Mode

If the [Pause] button is pressed during a Run sequence, the motor will stop. Press the [Pause] button again to continue the Run sequence. While the motor is stopped in PAUSE, a Pause-Mode Speed may be entered via the keypad. This new speed will operate when PAUSE is released by pressing the [Pause] button again, and will be retained while in Pause-Mode. Pressing any other control button than [Pause] will exit the Pause-Mode and return to the Preset Speed.

**Note:** the Pause-Mode Speed is indicated by an "\*" on the top line display thus:

(MANUAL)   PAUSE   * 2.34567 mm/min
-------------------------------------

#### 6.5 Serial Mode

The display will show:

(RS232) = STOP = 0.00000 mm/min [ ]RX TX[ ]
--

The top line shows the system status and the requested speed.

The bottom line shows the Received Characters (Rx) on the left and Transmitted Characters (Tx) on the right.

The speed and direction may be remotely controlled, by a computer or terminal, via the serial interface.

The speed may be programmed over the range 0.00000 to 9.99999 mm/min for metric, or 0.000000 to 0.399999 in/min for Imperial units. The direction is controlled by a leading '+' or '-' character (+ for UP, - for DOWN). Positive (UP) speeds may also be entered without a leading '+' symbol.

Example: for speed of 3.25400 mm/min or 0.125400 in/min in the UP direction, the following ASCII string would be sent:

(+)3.25400 (metric) or (+)0.125400 (Imperial), '+' not necessary for UP speeds.

All serial command strings must be terminated with the receive terminator as selected in the Serial Interface Set-Up (see later).

If the command string is accepted by the system, it will be returned to the source along with the transmit terminator.

If the motor is inhibited from moving in the requested direction, because it is at a limit switch or at the MAX position (see later), the following string will be returned:

+0.00000 (metric) or +0.000000 (Imperial)

If the command string is incorrectly formed, or the wrong termination is used, the following string will be returned:

\* COMMAND ERROR \*

Again, the selected transmit termination will be appended to these strings.

The sequence of Command/Reply must be maintained by the source controller at all times.

When the Mode is changed from Manual to Serial, the motor will stop and remain stopped until a serial command is received.

Press the [Stop] Command Push Button to manually override any serial command and force the motor to stop.

Use the [Mode] key (see earlier) to select any of the alternative operating modes.

## 6.6 Additional Serial Commands (Metric)

Command	Reply	Function
VSN	V **.*	Echo firmware release version number **.*
FAST +	FAST +	Ram moves UP at 40 mm/min for 250 mS
FAST -	FAST -	Ram moves DOWN at 40 mm/min for 250 mS
MAX +**	MAX +**	Set Upper Limit at **mm from current position
MAX -**	MAX -**	Set Lower Limit at **mm from current position
		Power-up default is $\pm 99$ mm
POSN	+***	Echo current position $\pm$ *** mm relative to point at which last MAX command was issued.
STATUS	ABCDEFGHIJ	Echo system status
	A	Motor Stopped
	B	Motor Moving UP
	C	Motor moving DOWN
	D	Ram limit UP
	E	Ram limit DOWN
	F	MAX limit UP
	G	MAX limit DOWN
	H	Stepper fault
	I	For future use
	J	For future use
		Any status code that is not valid will be replaced by a period (.) character.
DATUM	DAT-0	Set Datum for RETURN at current position. A symbol will show in the display to indicate that the datum has been set.
RETURN	RET-0	Return-To-Datum position (if Datum set) NO-DATUM if Datum has not been set since power-up.
HOME	HOME	Return to the bottom limit switch.
XSW	000000	Echo switch status.

### 6.7 Alternative Serial Commands (Imperial)

Command	Reply	Function
MAX +*.*	MAX +*.*	Set Upper Limit at *.* in from current position.
MAX -*.*	MAX -*.*	Set Lower Limit at *.* in from current position. Power-up default is $\pm 3.9$ in. Maximum range is $\pm 3.9$ in.
POSN	+*.*	Echo current position $\pm$ *.* in relation to point at which last MAX command was issued.

### 6.8 Return-To-Datum

Position the system at the required Datum Position.

Press the [Mode] key until the bottom line display shows:

```
[Enter] [Mode] : Set 0 Datum      [Esc]
```

Press the [Ent] key to datum an internal position counter to 0.

The display will revert to the current bottom line, and a  $\Downarrow$  symbol will appear on the top line to indicate that the datum has been set. Press the [ $\Downarrow$ ] key, at any time after setting the datum, to initiate a Return-To-Datum at the Fast Speed. The motor will stop at the Datum Position. The Return-To-Datum sequence may be terminated by pressing any of the other Command Push Buttons. The Datum may be cleared by selecting Manual Mode.

### 6.9 Set-Up Mode

The display will show the <SET-UP> Menu:

```
(SETUP)      [1]:Units - **/min  
              [2]:Serial Interface [ $\Downarrow$ ] [Esc]
```

Press the [1] key to toggle the operating units between 'mm/min' and 'in/min'.

Press the [2] key to configure the Serial Interface.

Press the [ $\Downarrow$ ] key to show setup options [3] & [4].

Press the [3] key to select System Options (service feature only, see Service Instructions – ELE document number 9904X0013).

Press the [4] key to select Diagnostics (service feature only, see Service Instructions – ELE document number 9904X0013).

Press the [Esc] key to return to the current Operating Mode.

## 6.10 Set-Up Serial Interface

The display will show:

(SETUP)	= STOP =	x.xxxxx mm/min
Baud Rate : 9600	*	[↑][↓][Enter][Esc]

Press the [↑] or [↓] keys until the desired setting is indicated.

The current setting is indicated by the presence of an asterisk (\*) next to the value.

Press [Enter] to select the indicated value and to step on to the next configuration parameter in the sequence. If a value is changed, then the [Enter] key must be pressed to save the new selection.

Press the [Esc] key to return to the (SET-UP) Menu, when the settings are satisfactory.

Available serial settings are as follows:

'Baud Rate'	1200, 2400, 4800, 9600 or 19200
'Rx. Term.'	CR, LF, CRLF or LFCR
'Tx. Term.'	CR, LF, CRLF or LFCR
'Echo Mode'	Off or On

**Note:** Echo Mode, when set to On, is for use with a dumb terminal. All received characters will be echoed back to the terminal.

## 6.11 E-Stop and Safety/ID

The latest version of the Tritest 50 has the addition of an E-Stop on its front panel. Pressing this in will immediately bring the units platen to a stop. Releasing the E-stop will allow the motion of the platen to continue. Care must be taken to resolve the conditions that required the E-Stop to be pressed prior to releasing it.

The Safety/ID input at the rear of the unit is available to interface to other ELE equipment.

## 7 Operation

Position the Crosshead (see section 3.3).

In order to retain maximum platen travel, it is suggested that any test is started with the platen set approximately 10 mm up from its lowest position.

Assemble the test apparatus in the load frame and take up excess clearance.

Select the speed required.

Note: a slight buzzing sound may be noticed at low speed. This is quite normal and may be ignored. It will disappear once the machines have been loaded.

To raise the platen at the commencement of a test, press the run button on the front panel. The readout will confirm commencement and direction of platen travel.

The speed may be altered at any time during a test.

To lower the platen at the completion of a test, press the STOP button followed by the FAST DOWN button.

If the mains power supply to the machine is interrupted at a load in excess of 25 kN, the machine will unload itself to approximately this figure.

## 8 Maintenance

**DANGER:** Servicing of this equipment must be performed by a qualified ELE service technician. Before removing any covers or performing maintenance repair and service, isolate from electrical supply by removing mains plug. Where mains supply connection is required during these activities, only fully trained technicians should perform the work.

**DANGER:** Always disconnect machine from mains before carrying out any adjustment or maintenance work.

Clean the outside of the machine only using a damp cloth, and a little non-scouring detergent if necessary.

It is suggested that to ensure satisfactory service from the machine, the following procedure is adopted.

Each time machine is used, lightly oil surface of platen (5) (figure 1).

Each month very lightly oil the column top threads and platen.

Every 6 months lubricate ball screw thread by unscrewing platen (5) (figure 1) complete with shroud and applying 2 or 3 squirts of 20 W/50 oil into the exposed hole in the centre of the ram.

**Fuse Replacement:** This machine is dual pole fused having both line and neutral fused, hence the two fuses.

**DANGER:** Always replace fuses with fuses of the same type and rating.

To replace or check a fuse, pull the fuseholder drawer from the power inlet module. (See Figure 3, Item 3 for fuse location). If necessary, replace the failed fuse/s with a fuse of the same type and rating (T 1.6A, 250V). The T 1.6A, 250V fuses are suitable for either 115 or 230 volt operation. Properly orient the fuseholder for the desired line voltage by aligning the voltage setting on the fuseholder drawer. The desired voltage setting (i.e. 110-120V or 220-240V) must be upright at the base of the fuseholder drawer; the selected voltage indicator's arrow will be pointing down. When properly oriented, push the fuseholder drawer into the power inlet module for the desired line voltage.

**DANGER:** Misapplication of the voltage can result in both electrical hazards and damage to the equipment.

**Important Note:** Fuse failures generally indicate an electrical problem with the equipment. If problem persists contact ELE for machine servicing.

## 9 Accessories

### 25-3479

Platen Adapter. For 159 mm (6¼ inch) diameter recessed triaxial cell bases.

## 10 Certifications

CE – see Declaration of Conformity at end of this document (All models)



## 11 Appendix A: RS232

A1 Communication connection

A1.1 Rear panel connector (4) (figure 3) 9-way male D type.

The Tritest is configured to behave as 'Data Terminal Equipment' (DTE).

Pin No.	Assignment	Comment
2	RXD	Receive data
3	TXD	Transmit data
5	Signal ground	

**Note:** A minimum connection of pins 2, 3 and 5 are required on the RS232 lead.

A 'cross-over' cable is required when connecting a host computer to the Tritest. This style of cable will have pins 2 – 3 and 3 – 2 connected (*see below*). Linking of the handshake lines, pins 1 – 4 – 6 and pins 7 – 8 may also be necessary at the host computer end of the cable. Because both the PC and Tritest require the same style of connector, it would be wise to insert these links to both connectors.

The wiring connection format for all IBM compatible PC's is shown in figure 4.

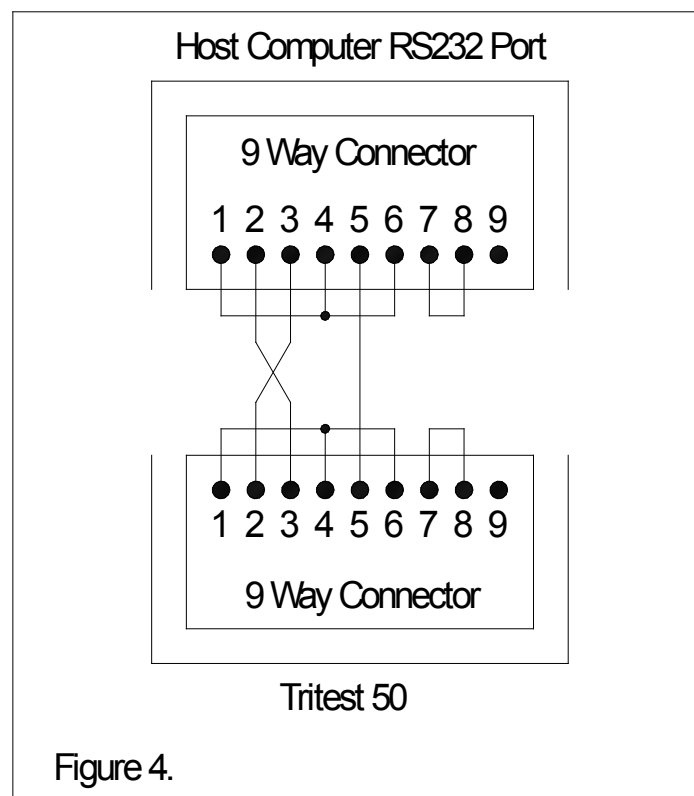

**DANGER - Externally connected equipment must have an applicable country safety standard assessment.**

## EC DECLARATION OF CONFORMITY



The Original Declaration of Conformity is suitable to Decision No 768/2008/EC of the European Parliament and the Council of 9<sup>th</sup> July 2008 on a common framework for the marketing of products and contains the elements specified in the relevant modules set out in Annex II of that Decision for the applicable Directives.

This declaration relates exclusively to the equipment in the state in which it was placed on the market and excludes components which are added and/or operations carried out subsequently by the final user.

### Applied Council Directive(s)

The fulfilment of all relevant provisions specified in Council Directive(s)

2014/30/EU Electromagnetic Compatibility (EMC)  
2006/42/EC Machinery Directive, Essential Health and Safety Requirements  
2011/65/EU RoHS2 Directive and Commission Delegated Directive (EU)2015/863

have been demonstrated.

We, the Manufacturer:

**ELE International**, Chartmoor Road, Chartwell Business Park, Leighton Buzzard  
Bedfordshire LU7 4WG, UK

declare under our sole responsibility that the following equipment:

**Product: Tritest 50 1936B0001 and 1884B0001**  
**Catalogue Number: 25-3518/01**

**Description: Compression frame for geotechnical sample testing**

The object of the declaration described above is in conformity with the relevant Union Harmonisation Decision and the provisions of the following standard(s) or other normative document(s) when installed in conformance with the installation instructions contained in the product documentation.

### EMC

Emissions: EN61326-1:2013, Class B

Immunity: EN61326-1:2013

Clauses pertinent to the Machinery Directive of

EN61010-1:2010 Safety requirements for electrical equipment for measurement, control and laboratory use – Part 1 General Requirements.

RoHs2: EN50581:2012 Technical documentation for the assessment of electrical and electronic products with respect to the restriction of hazardous substances.

The technical file's authorised compiler (named below) is at the address above.

We, the undersigned, hereby declare that the product(s) specified above conform to the listed directive(s) and Standard(s).

Date of issue: 17/01/2017

Signed

A handwritten signature in black ink, appearing to read 'Tony Power', written over a light blue grid background.

Name: Tony Power  
Position: Managing Director

BS EN ISO9001:2008 approved Certificate number 860461
--

9901X0252 Issue 6

Standard FCC and IC statements:

Canadian Radio Interference-Causing Equipment Regulation, IECS-003, Class A:  
Supporting test records reside with the manufacturer.

This Class A digital apparatus meets all requirements of the Canadian Interference-Causing Equipment Regulations.

Cet appareil numérique de la classe A respecte toutes les exigences du Règlement sur le matériel brouilleur du Canada.

FCC Part 15, Class "A" Limits

Supporting test records reside with the manufacturer. The device complies with Part 15 of the FCC Rules. Operation is subject to the following conditions:

1. The equipment may not cause harmful interference.
2. The equipment must accept any interference received, including interference that may cause undesired operation.

Changes or modifications to this equipment not expressly approved by the party responsible for compliance could void the user's authority to operate the equipment. This equipment has been tested and found to comply with the limits for a Class A digital device, pursuant to Part 15 of the FCC rules.

These limits are designed to provide reasonable protection against harmful interference when the equipment is operated in a commercial environment. This equipment generates, uses and can radiate radio frequency energy and, if not installed and used in accordance with the instruction manual, may cause harmful interference to radio communications.

Operation of this equipment in a residential area is likely to cause harmful interference, in which case the user will be required to correct the interference at their expense. The following techniques can be used to reduce interference problems:

1. Disconnect the equipment from its power source to verify that it is or is not the source of the interference.
2. If the equipment is connected to the same outlet as the device experiencing interference, connect the equipment to a different outlet.
3. Move the equipment away from the device receiving the interference.
4. Reposition the receiving antenna for the device receiving the interference.
5. Try combinations of the above.

## DIRECTIVE ON WASTE ELECTRICAL & ELECTRONIC EQUIPMENT (WEEE)



Electrical equipment marked with this symbol may not be disposed of in European public disposal systems after 12 August of 2005. In conformity with European local and national regulations (EU Directive 2002/96/EC), European electrical equipment users must now return old or end-of life equipment to the Producer for disposal at no charge to the user.

**Note:** For return for recycling, please contact the equipment producer or supplier for instructions on how to return end-of-life equipment for proper disposal.

**Important document. Retain with product records.**

### GERMAN

Elektrogeräte, die mit diesem Symbol gekennzeichnet sind, dürfen in Europa nach dem 12. August 2005 nicht mehr über die öffentliche Abfallentsorgung entsorgt werden. In Übereinstimmung mit lokalen und nationalen europäischen Bestimmungen (EU-Richtlinie 2002/96/EC), müssen Benutzer von Elektrogeräten in Europa ab diesem Zeitpunkt alte bzw. zu verschrottende Geräte zur Entsorgung kostenfrei an den Hersteller zurückgeben.

**Hinweis:** Bitte wenden Sie sich an den Hersteller bzw. an den Händler, von dem Sie das Gerät bezogen haben, um Informationen zur Rückgabe des Altgeräts zur ordnungsgemäßen Entsorgung zu erhalten.

**Wichtige Informationen. Bitte zusammen mit den Produktinformationen aufbewahren.**

### FRENCH

A partir du 12 août 2005, il est interdit de mettre au rebut le matériel électrique marqué de ce symbole par les voies habituelles de déchetterie publique. Conformément à la réglementation européenne (directive UE 2002/96/EC), les utilisateurs de matériel électrique en Europe doivent désormais retourner le matériel usé ou périmé au fabricant pour élimination, sans frais pour l'utilisateur.

**Remarque :** Veuillez vous adresser au fabricant ou au fournisseur du matériel pour les instructions de retour du matériel usé ou périmé aux fins d'élimination conforme.

**Ce document est important. Conservez-le dans le dossier du produit.**

### ITALIAN

Le apparecchiature elettriche con apposto questo simbolo non possono essere smaltite nelle discariche pubbliche europee successivamente al 12 agosto 2005. In conformità alle normative europee locali e nazionali (Direttiva UE 2002/96/EC), gli utilizzatori europei di apparecchiature elettriche devono restituire al produttore le apparecchiature vecchie o a fine vita per lo smaltimento senza alcun costo a carico dell'utilizzatore.

**Nota:** Per conoscere le modalità di restituzione delle apparecchiature a fine vita da riciclare, contattare il produttore o il fornitore dell'apparecchiatura per un corretto smaltimento.

**Documento importante. Conservare con la documentazione del prodotto.**

### DANISH

Elektriske apparater, der er mærket med dette symbol, må ikke bortskaffes i europæiske offentlige affaldssystemer efter den 12. august 2005. I henhold til europæiske lokale og nationale regler (EU-direktiv 2002/96/EF) skal europæiske brugere af elektriske apparater nu returnere gamle eller udtjente apparater til producenten med henblik på bortskaffelse uden omkostninger for brugeren.

**Bemærk:** I forbindelse med returnering til genbrug skal du kontakte producenten eller leverandøren af apparatet for at få instruktioner om, hvordan udtjente apparater bortskaffes korrekt.

**Vigtigt dokument. Opbevares sammen med produktdokumenterne.**

## SWEDISH

Elektronikutrustning som är märkt med denna symbol kanske inte kan lämnas in på europeiska offentliga sopstationer efter 2005-08-12. Enligt europeiska lokala och nationella föreskrifter (EU-direktiv 2002/96/EC) måste användare av elektronikutrustning i Europa nu återlämna gammal eller uttrangerad utrustning till tillverkaren för kassering utan kostnad för användaren.

**Obs!** Om du ska återlämna utrustning för återvinning ska du kontakta tillverkaren av utrustningen eller återförsäljaren för att få anvisningar om hur du återlämnar kasserad utrustning för att den ska bortskaffas på rätt sätt.

**Viktigt dokument. Spara tillsammans med dina produktbeskrivningar.**

## SPANISH

A partir del 12 de agosto de 2005, los equipos eléctricos que lleven este símbolo no deberán ser desechados en los puntos limpios europeos. De conformidad con las normativas europeas locales y nacionales (Directiva de la UE 2002/96/EC), a partir de esa fecha, los usuarios europeos de equipos eléctricos deberán devolver los equipos usados u obsoletos al fabricante de los mismos para su reciclado, sin coste alguno para el usuario.

**Nota:** *Sírvase ponerse en contacto con el fabricante o proveedor de los equipos para solicitar instrucciones sobre cómo devolver los equipos obsoletos para su correcto reciclado.*

**Documento importante. Guardar junto con los registros de los equipos.**

## DUTCH

Elektrische apparatuur die is voorzien van dit symbool mag na 12 augustus 2005 niet meer worden afgevoerd naar Europese openbare afvalsystemen. Conform Europese lokale en nationale wetgeving (EU-richtlijn 2002/96/EC) dienen gebruikers van elektrische apparaten voortaan hun oude of afgedankte apparatuur kosteloos voor recycling of vernietiging naar de producent terug te brengen.

**Nota:** *Als u apparatuur voor recycling terugbrengt, moet u contact opnemen met de producent of leverancier voor instructies voor het terugbrengen van de afgedankte apparatuur voor een juiste verwerking.*

**Belangrijk document. Bewaar het bij de productpapieren.**

## POLISH

Sprzęt elektryczny oznaczony takim symbolem nie może być likwidowany w europejskich systemach utylizacji po dniu 12 sierpnia 2005. Zgodnie z europejskimi, lokalnymi i państwowymi przepisami prawa (Dyrektywa Unii Europejskiej 2002/96/EC), użytkownicy sprzętu elektrycznego w Europie muszą obecnie przekazywać Producentowi stary sprzęt lub sprzęt po okresie użytkowania do bezpłatnej utylizacji.

**Uwaga:** *Aby przekazać sprzęt do recyklingu, należy zwrócić się do producenta lub dostawcy sprzętu w celu uzyskania instrukcji dotyczących procedur przekazywania do utylizacji sprzętu po okresie użytkowania.*

**Ważny dokument. Zachować z dokumentacją produktu.**

## PORTUGUESE

Qualquer equipamento eléctrico que ostente este símbolo não poderá ser eliminado através dos sistemas públicos europeus de tratamento de resíduos sólidos a partir de 12 de Agosto de 2005. De acordo com as normas locais e europeias (Directiva Europeia 2002/96/EC), os utilizadores europeus de equipamentos eléctricos deverão agora devolver os seus equipamentos velhos ou em fim de vida ao produtor para o respectivo tratamento sem quaisquer custos para o utilizador.

**Nota:** *No que toca à devolução para reciclagem, por favor, contacte o produtor ou fornecedor do equipamento para instruções de devolução de equipamento em fim de vida para a sua correcta eliminação.*

**Documento importante. Mantenha junto dos registos do produto.**